

FLUID  
FLYWHEEL

**FLUID FLYWHEEL**  
railcar.co.uk

# 18" DIA. FLUID FLYWHEEL SECTION

(A.E.C. TYPE UNITS)

## TYPES

J156J  
J156M

## D.T.O.

1/3, 1/6, 1/7, 1/11, 1/11B, 1/20,  
1/B, 1/2, 1/5

railcar.co.uk

**NUMERICAL INDEX TO PART NUMBERS**

Manufacturer's Basic Part No.	B.R. Catalogue No.	Page	Manufacturer's Basic Part No.	B.R. Catalogue No.	Page
A72327	9/15/43007	J1			
A82502	9/15/43052	J2			
A2/19448	9/15/43051	J2			
J156J	9/15/43000	J1			
J156M	9/15/43001	J1			
J0140	9/15/43003	J1			
J2142	9/15/43015	J1			
J2143	9/15/43014	J1			
J4302	9/15/43024	J1			
J10120	9/15/43028	J1			
J14521	9/15/43043	J1			
J22803	9/15/43019	J1			
J22903	9/15/43016	J1			
J24107	9/15/43005	J1			
J25416	9/15/43004	J1			
J25507		J1			
J25603	9/15/43049	J2			
J27903	9/15/43040	J1			
K10249	9/15/43030	J1			
K22964	9/15/43029	J1			
Z10120	9/15/43022	J1			
Z43970	9/15/43035	J1			
Z44981	9/15/43058	J1			
Z1/30716	9/15/30581	J2			
Z1/31995	9/15/43053	J2			
Z2/31953	9/15/43037	J1			
Z3/10238	9/15/43045	J1			
Z3/30792	9/15/43020	J1			
Z3/43705	9/15/43008	J1			
Z5/30634	9/15/43010	J1			
Z5/44864	9/15/43055	J2			
Z15/30770	9/15/43021	J1			
2-40	9/43/6028	J1			
15-33	9/43/34075	J2			
40-34	9/15/43042	J1			
41-63	9/15/43002	J2			
81-2338	9/15/43032	J1			
81-2339	9/15/43033	J1			
86-33		J1			
86-34		J1			
99-44		J2			
100-4		J1			
100-10		J1			
100-12		J2			
100-43		J1			
103-89	9/15/43041	J1			
117-75	9/15/43009	J1			
134-3		J1			
135-33		J1			
135-34		J2			
138-144	9/15/35382	J1			
219-21		J1			

B.R. Cat. No.	A.E.C. Basic Part No.	Plate Ref.	Designation	Used on	No. Req. per Fluid Flywheel	Remarks
9/15/43000	J156J	J1	<b>FLUID FLYWHEEL COMPLETE</b> ... ..	See front page	1	Dished Coupling } With Section A.51
9/15/43001	J156M		<b>FLUID FLYWHEEL COMPLETE</b> ... ..	"	1	Flat Coupling }
9/15/43003	J0140		<b>FRONT CASING WITH STARTER RING...</b>	All Models	1	
9/15/43004	J25416	1	Casing, Front ... ..	"	1	
9/15/43007	A72327	2	<b>Ring, Starter</b> ... ..	"	1	
9/15/43005	J24107	3	Key, Special ... ..	"	1	
9/15/43009	I17-75	5	Screw, Csk., $\frac{1}{4}$ " B.S.F. $\times$ $\frac{5}{8}$ ", Special ... ..	"	1	
9/15/43008	Z3/43705	6	Screw, Special, $\frac{1}{4}$ " B.S.F. $\times$ $\frac{5}{8}$ ", Drilled ... ..	"	10	} Front Casing
9/15/43010	Z5/30634	7	Washer, Special, 12 S.W.G. ... ..	"	10	
	219-21	8	Wire, Locking, Iron, 16 S.W.G. ... ..	"	2' 6"	
9/15/43014	J2143		<b>REAR CASING WITH RUNNER SHAFT COMPLETE</b> ... ..	J156J	1	
9/15/43015	J2142		<b>REAR CASING WITH RUNNER SHAFT COMPLETE</b> ... ..	J156M	1	
9/15/43024	J4302	9	<b>RUNNER CASING COMPLETE</b> ... ..	All Models	1	
	J25507		Casing, Runner ... ..	"	1	} Not supplied as Spares
9/15/43043	J14521	10	Shaft, Runner ... ..	"	1	
9/15/43020	Z3/30792	11	Bolt, Special, $\frac{3}{8}$ " B.S.F. $\times$ 32 m/m. ... ..	"	6	} Runner Shaft to Runner Casing
9/15/43022	Z10120	12	Bush, Bolt, Special ... ..	"	6	
	86-34	} 13	Nut, Slotted, $\frac{3}{8}$ " B.S.F. ... ..	"	6	
	100-10		Split Pin, $\frac{3}{32}$ " $\times$ $\frac{7}{8}$ " ... ..	"	6	
9/15/43040	J27903	14	Plate, Oil Deflector ... ..	"	1	} Oil Deflector Plate to Runner Casing
9/15/43021	Z15/30770	15	Bolt, Special, $\frac{5}{16}$ " B.S.F. $\times$ $1\frac{1}{2}$ ", Drilled ... ..	"	6	
	86-33	} 16	Nut, Slotted, $\frac{5}{16}$ " B.S.F. ... ..	"	6	
	134-3		Washer, Plain, $\frac{5}{16}$ " ... ..	"	6	
	100-4		Split Pin, $\frac{1}{16}$ " $\times$ 1" ... ..	"	6	
9/15/43028	J10120	17	Casing, Rear ... ..	"	1	} Rear Casing
9/15/43041	103-89	18	Plug, Filler ... ..	"	4	
9/15/35382	138-144	19	Washer, Copper, 27 $\times$ 34 $\times$ 2.5 m/m., Special ... ..	"	4	
9/43/6028	2-40	20	<b>Bearing, Ball, Hoffmann No. 345, R. &amp; M. No. MJ.45, "OOO" Fit</b> ... ..	"	1	
9/15/43058	Z44981	21	Washer, Bearing ... ..	"	1	
9/15/43032	81-2338	22	<b>Gland Seal, British Thermostat No. BGA5610</b> ... ..	"	1	} Gland to Ring
9/15/43033	81-2339	23	Ring, Rubbing, British Thermostat No. BGB111 ... ..	"	1	
9/15/43035	Z43970	24	<b>Joint...</b> ... ..	"	1	
9/15/43016	J22903	25	Adaptor Ring ... ..	"	1	} Gland to Casing
9/15/43019	J22803	26	Ring Bolt, Special ... ..	"	1	
9/15/43042	40-34	} 27	Bolt, $\frac{5}{16}$ " B.S.F. $\times$ $1\frac{1}{4}$ ", Special, Drilled ... ..	"	6	
	135-33		Washer, Grover, $\frac{5}{16}$ " ... ..	"	6	
9/15/43045	Z3/10238	28	Sleeve, Coupling Flange ... ..	J156M	1	} Flat
9/15/43030	K10249	29	Flange, Coupling ... ..	J156J	1	
9/15/43029	K22964	30	Flange, Coupling ... ..	All Models	1	} Coupling Flange to Runner Shaft
9/15/43037	Z2/31953	31	Nut, Special, $1\frac{1}{8}$ " B.S.F., Slotted, $\frac{1}{16}$ " Thick ... ..	"	1	
	100-43	32	Split Pin, $\frac{3}{16}$ " $\times$ 2" ... ..	"	1	

B.R. Cat. No.	A.E.C. Basic Part No.	Plate Ref.	Designation	Used on	No. Req. per Fluid Flywheel	Remarks
		<b>J1</b>	<b>FLUID FLYWHEEL—Continued</b>			
9/15/43049	J25603	33	<b>Joint</b> ... ..	All Models	1	} Front to Rear Casing
9/15/43002	41-63	} 34	Bolt, $\frac{3}{8}$ " B.S.F. $\times$ $1\frac{1}{4}$ ", Special ... ..	"	20	
	135-34		Washer, Grover, $\frac{3}{8}$ " ... ..	"	20	
9/43/34075	15-33	35	<b>Bearing, Roller, Hoffmann No. L3281, R. &amp; M. No. MRJ25, "OOO" Fit</b> ... ..	"	1	} Runner Shaft
	99-44	36	Circlip, Seeger, G.P. Dia., 25 m/m... ..	"	1	
9/15/43055	Z5/44864	37	Ring, Distance ... ..	"	1	} Flywheel to Crankshaft
9/15/43052	A82502	38	<b>Packing, Felt</b> ... ..	"	1	
9/15/30581	Z1/30716	39	Bolt, Special, $\frac{1}{2}$ " B.S.F. $\times$ 38 m/m., Drilled ... ..	"	6	
9/15/43053	Z1/31995	} 40	Nut, Special, $\frac{1}{2}$ " B.S.F., Slotted... ..	"	6	
	100-12		Split Pin, $\frac{3}{32}$ " $\times$ $1\frac{1}{8}$ " ... ..	"	6	
9/15/43051	A2/19448	41	<b>Joint</b> ... ..	"	1	
			<b>NOTE:—For Fluid Flywheel Bolts, see also Engine Section A.51</b>			

railcar.co.uk

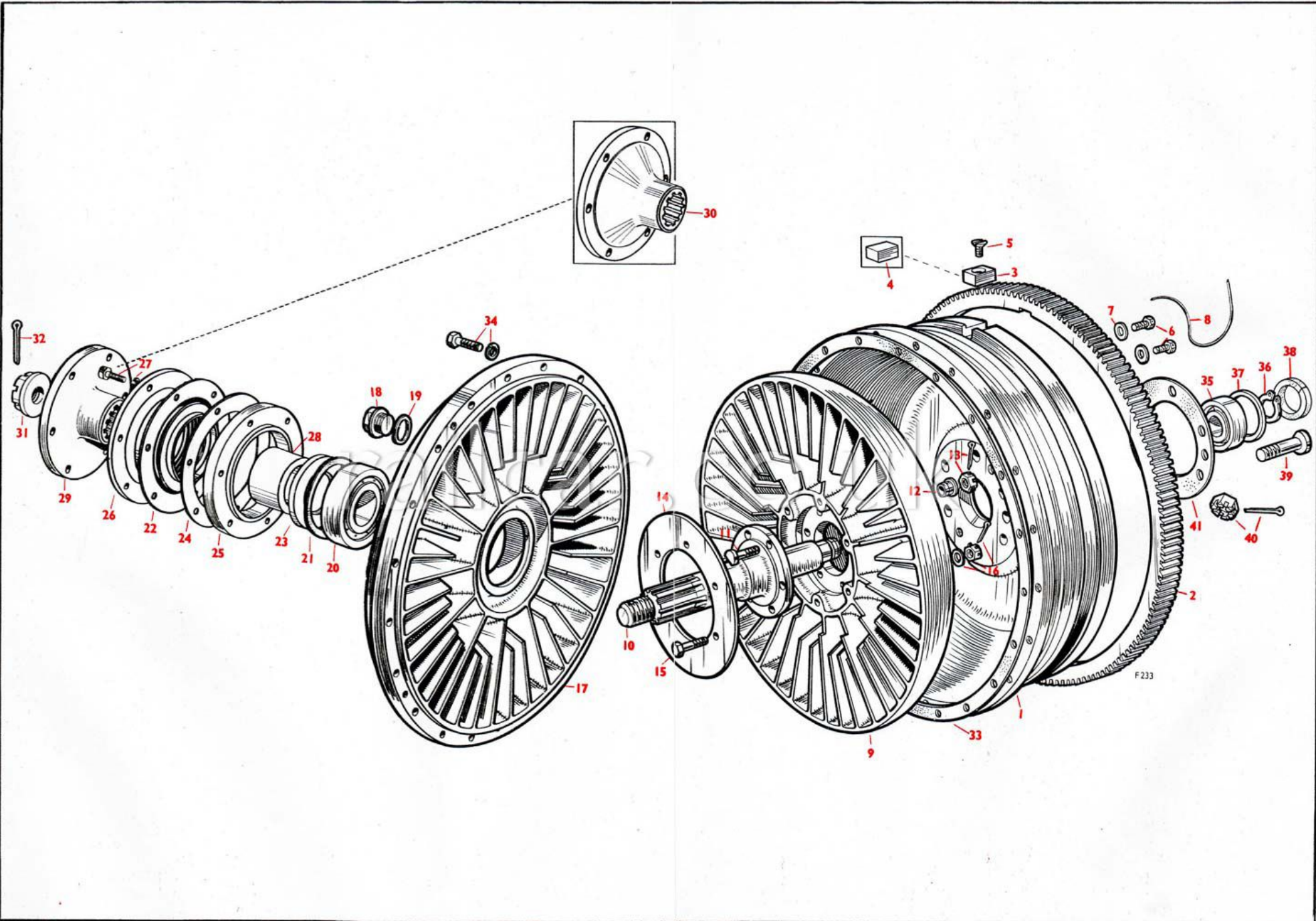

# FLUID FLYWHEEL SECTION

(A.E.C. TYPE UNIT)

TYPE

J176A  
(20" DIA.)

railcar.co.uk

**NUMERICAL INDEX TO PART NUMBERS**

Manufacturer's Basic Part No.	B.R. Catalogue No.	Page	Manufacturer's Basic Part No.	B.R. Catalogue No.	Page
A72327	9/15/43007	J1			
A2/19448	9/15/43051	J1			
F11322	9/15/43087	J1			
J176A	9/15/43065	J1			
J0142	9/15/43069	J1			
J2148	9/15/43074	J1			
J4304	9/15/43080	J1			
J10124	9/15/43082	J1			
J14525	9/15/43093	J1			
J22804	9/15/43076	J1			
J22904	9/15/43068	J1			
J24107	9/15/43005	J1			
J25418	9/15/43070	J1			
J25509		J1			
J27908	9/15/43091	J1			
K1/22901	9/15/43083	J1			
Z10120	9/15/43022	J1			
Z43977	9/15/43098	J1			
Z43978	9/15/43088	J1			
Z43982	9/15/43096	J1			
Z1/30716	9/15/30581	J1			
Z1/31995	9/15/43053	J1			
Z2/31954	9/15/43090	J1			
Z3/43705	9/15/43008	J1			
Z5/30634	9/15/43010	J1			
Z8/30731	9/15/43078	J1			
Z18/30726	9/15/43077	J1			
6-122	9/43/6718	J1			
15-15	9/43/34096	J1			
40-33	9/15/43092	J1			
41-64	9/15/43066	J1			
81-2438	9/15/43085	J1			
86-34		J1			
99-54		J1			
100-4		J1			
100-12		J1			
100-43		J1			
103-89	9/15/43082	J1			
117-75	9/15/43009	J1			
134-4		J1			
135-33		J1			
135-34		J1			
138-144	9/15/35382	J1			
219-21		J1			

railcar.co.uk



B.R. Cat. No.	A.E.C. Basic Part No.	Plate Ref.	Designation	Used on	No. Req. per Fluid Flywheel	Remarks	
9/15/43065	J176A	J1	<b>FLUID FLYWHEEL COMPLETE</b> ... ..	All Models	1	With Section A52	
9/15/43069	J0142		<b>FRONT CASING WITH STARTER RING</b> ...	"	1	} Front Casing	
9/15/43070	J25418	1	Casing, Front ... ..	"	1		
9/15/43007	A72327	2	<b>Ring, Starter</b> ... ..	"	1		
9/15/43005	J24107	3	Key, Special ... ..	"	1		
9/15/43009	117-75	5	Screw, Csk., $\frac{1}{4}$ " B.S.F. $\times \frac{5}{8}$ ", Special ... ..	"	1		
9/15/43008	Z3/43705	6	Screw, Special, $\frac{1}{4}$ " B.S.F. $\times \frac{5}{8}$ " Long ... ..	"	10		
9/15/43010	Z5/30634	7	Washer, Special, 12 S.W.G. ... ..	"	10		
	219-21	8	Wire, Locking, Iron, 16 S.W.G. ... ..	"	2' 6"		
9/15/43074	J2148		<b>REAR CASING WITH RUNNER SHAFT COMPLETE</b> ... ..	"	1	} Not Supplied as Spares	
9/15/43080	J4304	9	<b>RUNNER CASING COMPLETE</b> ... ..	"	1		
	J25509		Casing, Runner ... ..	"	1		
9/15/43093	J14525	10	Shaft, Runner ... ..	"	1		
9/15/43077	Z18/30726	11	Bolt, Special, $\frac{3}{8}$ " B.S.F. $\times 1\frac{3}{8}$ " Long, Drilled ... ..	"	8		} Runner Shaft to Runner Casing
9/15/43022	Z10120	12	Bush, Bolt, Special ... ..	"	8		
	86-34	13	Nut, Slotted, $\frac{3}{8}$ " B.S.F. ... ..	"	8		} Oil Deflector Plate to Runner Shaft
	100-4		Split Pin, $\frac{1}{16}$ " $\times 1$ " ... ..	"	8		
9/15/43091	J27908	14	Plate, Oil Deflector ... ..	"	1		} Oil Deflector Plate to Runner Shaft
9/15/43078	Z8/30731	15	Bolt, Special, $\frac{3}{8}$ " B.S.F. $\times 1\frac{3}{8}$ " Long, Drilled ... ..	"	8		
	86-34	16	Nut, Slotted, $\frac{3}{8}$ " B.S.F. ... ..	"	8		
	134-4		Washer, Plain, $\frac{3}{8}$ " ... ..	"	8		
	100-4		Split Pin, $\frac{1}{16}$ " $\times 1$ " ... ..	"	8		} Rear Casing
9/15/43082	J10124	17	Casing, Rear ... ..	"	1		
9/15/43041	103-89	18	Plug, Filler ... ..	"	4		
9/15/35382	138-144	19	Washer, Copper, 27 $\times$ 34 $\times$ 2.5 m/m., Special ... ..	"	4		
9/43/6718	6-122	20	<b>Bearing, Ball, Hoffmann No. 555, "OOO" Fit</b> ... ..	"	1		} Gland to Ring
9/15/43098	Z43977	21	<b>Joint...</b> ... ..	"	1		
9/15/43085	81-2438	22	<b>Gland Seal, British Thermostat No. DJS5047</b> ... ..	"	1		} Gland to Ring
9/15/43087	F11322	23	Ring, Rubbing ... ..	"	1		
9/15/43088	Z43978	24	<b>Joint...</b> ... ..	"	1	} Gland to Ring	
9/15/43068	J22904	25	Casing, Bearing ... ..	"	1		
9/15/43076	J22804	26	Ring Bolt ... ..	"	1	} Gland to Casing	
9/15/43092	40-33	27	Bolt, $\frac{5}{16}$ " B.S.F. $\times 1\frac{1}{8}$ " ... ..	"	8		
	135-33		Washer, Grover, $\frac{5}{16}$ " ... ..	"	8		
9/15/43083	K1/22901	30	Flange, Coupling ... ..	"	1	} Coupling Flange to Runner Shaft	
9/15/43090	Z2/31954	31	Nut, Special, $1\frac{1}{8}$ " B.S.F. Slotted, $1\frac{3}{8}$ " Thick ... ..	"	1		
	100-43	32	Split Pin, $\frac{3}{16}$ " $\times 2$ " ... ..	"	1	} Front to Rear Casing	
9/15/43096	Z43982	33	<b>Joint</b> ... ..	"	1		
9/15/43066	41-64	34	Bolt, $\frac{3}{8}$ " B.S.F. $\times 1\frac{3}{8}$ ", Special ... ..	"	26	} Front to Rear Casing	
	135-34		Washer, Grover, $\frac{3}{8}$ " ... ..	"	26		
9/43/34096	15-15	35	<b>Bearing, Roller, Hoffmann No. R335 "OOO" Fit</b> ... ..	"	1	} Flywheel to Crankshaft	
	99-54	36	Circlip, Seeger, G.P. Dia. 35 m/m. ... ..	"	1		
9/15/30581	Z1/30716	39	Bolt, Special, $\frac{1}{2}$ " B.S.F. $\times 38$ m/m., Drilled ... ..	"	6	} Flywheel to Crankshaft	
9/15/43053	Z1/31995	40	Nut, Special, $\frac{1}{2}$ " B.S.F., Slotted ... ..	"	6		
	100-12		Split Pin, $\frac{3}{32}$ " $\times 1\frac{1}{8}$ " ... ..	"	6		
9/15/43051	A2/19448	41	<b>Joint Matl. New. Re-maint. Graphited Joint. Old. Ok.</b> ... ..	"	1		

**NOTE:—For Flywheel Bolts, see also Engine Section A52**

