

SILENCER
railcar.co.uk

SILENCER

SILENCER AND EXHAUST PIPE SECTION

(A.E.C. TYPE UNITS)

TYPE
T134A

railcar.co.uk

NUMERICAL INDEX TO PART NUMBERS

Manufacturer's Basic Part No.	B.R. Catalogue No.	Page	Manufacturer's Basic Part No.	B.R. Catalogue No.	Page
T134A	9/15/63750	T1			
T0938	9/15/63751	T1			
T0939	9/15/63752	T1			
T0944	9/15/63753	T1			
T6/0269	9/15/63754	T1			
T11160	9/15/63760	T2			
T11161	9/15/63761	T2			
T13009	9/15/63758	T1			
T13010	9/15/63757	T1			
U182540	9/15/63755	T1			
U182541	9/15/63756	T1			
Z3/30748	9/15/40143	T2			
Z8/30746	9/15/65237	T1			
Z17/30702	9/15/63634	T1			
40-36	9/15/61028	T2			
41-61	9/15/65087	T1			
85-34		T1			
85-63		T2			
85-65	9/15/40311	T2			
86-35		T1			
100-10		T1			
135-33		T2			
135-34		T1			
135-35		T2			
216-151	9/15/63759	T1			

railcar.co.uk

B.R. Cat. No.	A.E.C. Basic Part No.	Plate Ref.	Designation	Used on	No. Req. per Silencer	Remarks
9/15/63750	T134A	T1 1	SILENCER COMPLETE, BURGESS, 400136	DT01/B, 1/2, 1/3, 1/5, 1/6, 1/7, 1/11, 1/12, 1/14, 1/16, 1/17, 1/11B, 1/22, 1/21, 1/20, 1/25, 1/26, 1/27, 1/31, 1/33, 1/32, 1/34, 1/40, 1/51, 1/55, 1/56	1	
9/15/63751	T0938	2	SILENCER STRAP COMPLETE ...	DT01/B, 1/2, 1/3, 1/5, 1/7,	1	Front
9/15/63634	Z17/30702	3	Bolt, Special, $\frac{7}{16}$ " x $2\frac{5}{8}$ ", Drilled ...	1/11, 1/12, 1/16, 1/11B, 1/20,	1	
	86-35	4	Nut, Slotted, $\frac{7}{16}$ " B.S.F. ...	1/23, 1/27, 1/31	1	
	100-10	5	Split Pin, $\frac{3}{32}$ " x $\frac{7}{8}$ " ...	"	1	
9/15/63752	T0939	6	SILENCER STRAP COMPLETE ...	DT01/B, 1/2, 1/3, 1/5, 1/7,	1	Rear
9/15/65087	41-61	7	Bolt, $\frac{3}{8}$ " B.S.F. x 1", Special, Drilled ...	1/11, 1/11B, 1/12, 1/16, 1/17,	2	
	85-34	8	Nut, Plain, $\frac{3}{8}$ " B.S.F. ...	1/20, 1/23, 1/25, 1/27, 1/31,	2	
	135-34	9	Washer, Grover, $\frac{3}{8}$ " ...	1/55, 1/56	2	
9/15/63753	T0944		SILENCER STRAP COMPLETE ...	DT01/14, 1/21, 1/33, 1/40	2	Front and Rear
9/15/65237	Z8/30746		Bolt, Special ...	"	2	
	86-35		Nut, Slotted, $\frac{7}{16}$ " B.S.F. ...	"	2	
	100-10		Split Pin, $\frac{3}{32}$ " x $\frac{7}{8}$ " ...	"	2	
9/15/63754	T6/0269		FLEXIBLE EXHAUST PIPE COMPLETE	DT01/B, 1/2, 1/3, 1/5, 1/6, 1/7, 1/11, 1/12, 1/14, 1/16, 1/17, 1/11B, 1/22, 1/21, 1/20, 1/23, 1/24, 1/25, 1/26, 1/27, 1/31, 1/33, 1/34, 1/40, 1/51, 1/55, 1/56	1	
		10				
9/15/63755	U182540		FLEXIBLE EXHAUST PIPE COMPLETE	DT01/32	1	21" Length 16" in uncontrolled condition
9/15/63756	U182541		FLEXIBLE EXHAUST PIPE COMPLETE		1	
9/15/63757	T13010	11	Spigot Piece, Exhaust Manifold ...	DT01/B, 1/2, 1/3, 1/5, 1/6, 1/7, 1/11, 1/12, 1/14, 1/16, 1/17, 1/11B, 1/20, 1/21, 1/22, 1/23, 1/25, 1/26, 1/27, 1/31, 1/32, 1/33, 1/34, 1/40, 1/51, 1/55, 1/56	1	
9/15/63758	T13009	12	Spigot Piece, Exhaust Pipe ...	DT01/B, 1/2, 1/3, 1/5, 1/6, 1/7, 1/11, 1/12, 1/14, 1/16, 1/17, 1/11B, 1/20, 1/22, 1/23, 1/25, 1/27, 1/31, 1/34, 1/51, 1/55, 1/56	11 *	6 off on DT01/21 9 off on DT01/26, 1/32 10 off on DT01/33, 1/40 4 off on DT01/24 *
9/15/63759	216-151	13	Pipe, Exhaust, 3" O/D. x 16 G. I/D. ...	DT01/B, 1/2, 1/3, 1/5, 1/6, 1/7, 1/11, 1/12, 1/14, 1/16, 1/17, 1/11B, 1/20, 1/22, 1/23, 1/25, 1/26, 1/27, 1/31, 1/32, 1/34, 1/51, 1/55, 1/56	10 ft.	

B.R. Cat. No.	A.E.C. Basic Part No.	Plate Ref.	Designation	Used on	No. Req. per Silencer	Remarks
		TI	EXHAUST PIPES AND FITTINGS—			
			Continued			
9/15/63760	T11160	14	Flange, 3 Holes	DTOI/B, 1/2, 1/3, 1/5, 1/6, 1/7, 1/11, 1/12, 1/14, 1/16, 1/17, 1/11B, 1/20, 1/22, 1/23, 1/24, 1/25, 1/27, 1/31, 1/33, 1/34, 1/40, 1/51, 1/55, 1/56	1	2 off on DTOI/21
9/15/63761	T11161	15	Flange, 4 Holes	DTOI/B, 1/2, 1/3, 1/5, 1/6, 1/7, 1/11, 1/12, 1/14, 1/16, 1/17, 1/11B, 1/20, 1/22, 1/23, 1/25, 1/27, 1/31, 1/34, 1/51, 1/55, 1/56	5	6 off on DTOI/21 7 off on DTOI/26, 1/32, 1/33, 1/40 1 off on DTOI/24
9/15/40143	Z3/30748	16	Bolt, Special, $\frac{7}{8}$ " B.S.F. \times $2\frac{1}{8}$ ", Drilled ...	DTOI/B, 1/2, 1/3, 1/5, 1/6, 1/7, 1/11, 1/12, 1/14, 1/16, 1/17, 1/11B, 1/20, 1/22, 1/23, 1/25, 1/27, 1/31, 1/34, 1/51, 1/55, 1/56	9*	6 off on DTOI/21 3 off on DTOI/26, 1/32 12 off on DTOI/33, 1/40*
9/15/40311	85-65	17	Nut, Plain, $\frac{7}{8}$ " B.S.F., "Rustless"...		9*	
	135-35	18	Washer, Grover, $\frac{7}{8}$ "		9*	
9/15/61028	40-36	19	Bolt, $\frac{5}{8}$ " B.S.F. \times $1\frac{1}{2}$ ", Special, Drilled ...	DTOI/B, 1/2, 1/3, 1/5, 1/6, 1/7, 1/11, 1/12, 1/14, 1/16, 1/17, 1/11B, 1/20, 1/23, 1/25, 1/27, 1/31, 1/33, 1/34, 1/40, 1/51, 1/55, 1/56	20	24 off on DTOI/21 36 off on DTOI/26, 1/32 7 off on DTOI/24
	85-63	20	Nut, Plain, $\frac{5}{8}$ " B.S.F., "Rustless"...		20	
	135-33	21	Washer, Grover, $\frac{5}{8}$ "		20	
<p>NOTE:—Quantities marked with an asterisk are total per car.</p> <p>DTOI/12—On 20 Power Cars of this Order only T6/0269 (1 off) and 40-36, 85-63, 135-33 (7 off) are supplied.</p> <p>DTOI/14—The Fittings on this Order are required for 24 Power Cars.</p> <p>DTOI/23—The Fittings on this Order are required for 6 Power Cars.</p>						

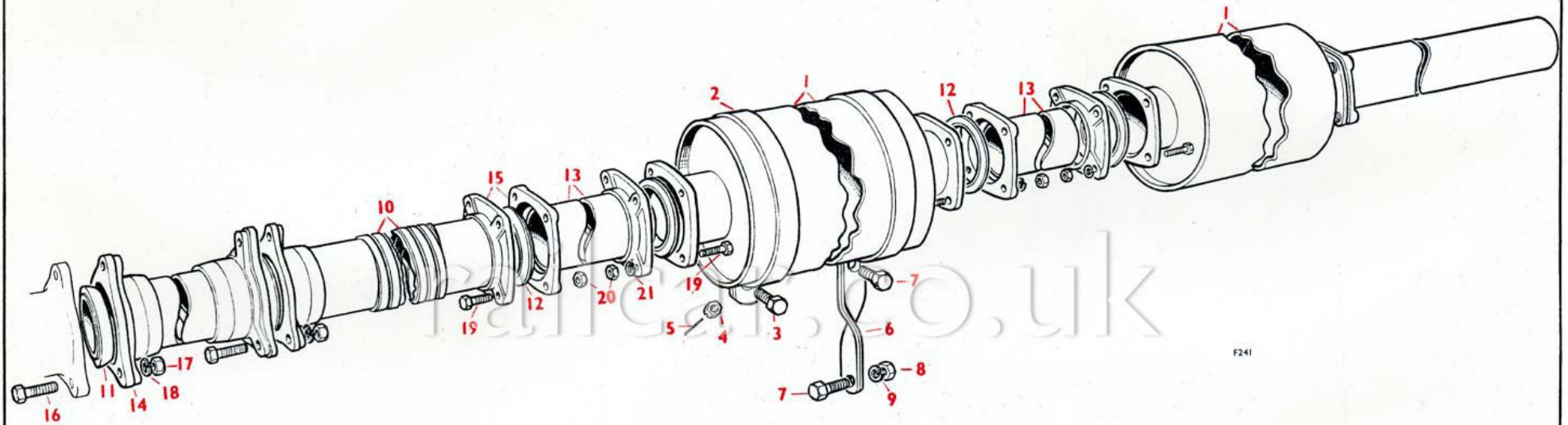

F241