

MT/261

British Railways Board

Mechanical & Electrical Engineering Department

DOOR LOCKS

TESTING



DOOR LOCKS TESTING
(following door open in motion or lock malfunction)

CONTENTS:

Clause.

1. INTRODUCTION
2. INITIAL EXAMINATION
3. RELEASE OF VEHICLE
4. DOCUMENTATION
5. BODYSIDE DOOR EXAMINATION
6. EMERGENCY BODYSIDE DOOR EXAMINATION
7. BENCH TESTING

APPENDICES:

- A. REPORTING FORM
- B. 1. SAFETY CATCH ENGAGEMENT
2. LENGTH OF LOCKBOLT
- C. USE OF LOCK BOLT FORCE TESTING DEVICE
- D. USE OF INSIDE ACTUATION FORCE TESTING DEVICE
- E. LOCK IDENTIFICATION

1. INTRODUCTION

- 1.1 This document details the procedure to be followed when:-
 - 1.1.1 A person has fallen from a passenger train.
 - 1.1.2 A bodyside door of a passenger carrying vehicle has been found open with the train in motion.
 - 1.1.3 It is alleged that a bodyside door of a passenger carrying vehicle opened whilst the train was in motion.
 - 1.1.4 A bodyside door lock has been found, or reported to have been found, stuck in the open position at any time excepting when it is being worked upon.
- 1.2 This procedure does not apply to guard's or van doors.

2. INITIAL EXAMINATION

- 2.1 If the incident occurs whilst the vehicle is in traffic then the door and lock must be checked immediately by a person competent to assess its condition. The following action must be taken:-
 - 2.1.1 The operation of the door and its mechanism must be checked and reported on, see Appendix A Initial Examination.
 - 2.1.2 If the door will not shut and/or lock, then the vehicle must not be used for conveying passengers. At the earliest possible opportunity the vehicle must be withdrawn from service and returned to a destination where checking in accordance with this document Chapters 5 or 6 and the necessary repair work can be carried out. The door must be secured in a manner sufficient to allow the vehicle to be safely moved.
 - 2.1.3 Shut and lock the door if possible. Plug the keyhole. Attach to the door the label BR 11548 "This door is not to be used". Attach labels BR 11224 to the vehicle right hand end (facing the side of the vehicle) footstep on both sides. At the end of the journey, for preference, but not later than the end of the days working, the vehicle must be withdrawn from service and returned to a destination where checking in accordance with this document Chapters 5 or 6 and the necessary repair work can be carried out.
- 2.2 If the incident occurs whilst the vehicle is out of traffic then the door and lock must be checked in accordance with this document Chapters 5 or 6 and the necessary repair work carried out. If it is necessary to move the vehicle then the door must be secured in a safe manner.

3. RELEASE OF VEHICLE

- 3.1 Vehicles stopped following an incident where a person has fallen from a train should not be repaired until the R.O.M. Signalling and Safety Officer is satisfied that all the necessary investigations and enquiries have been made. The RM & EE may then authorise the repair and release of the vehicle.
- 3.2 Doors, striking plates and locks can only be removed by permission of the RM & EE who, if the vehicle has been involved in an incident where a person has fallen from a train, must obtain the consent of the R.O.M. Signalling and Safety Officer for this action.
- 3.3 Removed locks shall have a label securely attached. The label shall have the following details clearly printed on it:-

Senders name and address
The vehicle number
Door number
Cross reference to In-situ Examination Report (Appendix A)
Date lock removed

The labelled lock shall be forwarded to the R.M. & E.E. either by registered post, by hand or other traceable means.

4. DOCUMENTATION

- 4.1 Full and precise details of the Initial Examination and the Bodyside Door Examination findings are to be entered on the report form detailed in Appendix 'A' if this document. A copy of the form must be sent to the RM & EE not later than two days following the incident.

5. BODYSIDE DOOR EXAMINATION

Note This procedures is to be followed in its entirety in the event of an incident as detailed in paras. 1.1.1 - 1.1.3 occurring. If an incident as detailed in para. 1.1.4 occurs then omit paras. 5.1.3 and 5.1.8. The results must be reported on, see Appendix A Bodyside Door Examination.

- 5.1 Check the following:-
- 5.1.1 The stepboard for fresh damage or marks.
- 5.1.2 The condition of the door check strap and door limit control (where fitted).
- 5.1.3 The side of the vehicle or of the adjacent vehicle for evidence of the door hinging right back. Note any marks made by the door handle.
- 5.1.4 The condition of the door hinges and the security of their fastenings.
- 5.1.5 The bodyside pillar guide plate and door lock pillar support plate for alignment and security of their fastenings.

- 5.1.6 The security of the fastenings of the door lock and the striking plate.
- 5.1.7 That the door lock bolt correctly leads onto the striking plate.
- 5.1.8 The position of the droplight lock and the ease of movement of the droplight.
- 5.1.9 With the door closed that there is clearance around the edges and that it does not bind in the frame.
- 5.2 Check the security of the door lock outside handle and its rose plate.
- 5.3 With the door open release the lock by depressing the bolt (single action) or the ram (double action) and note the manner in which the handle returns. Rotate the handle to the fully open position and note any binding or looseness. With locks having both inside and outside actuation again release the lock. Slide the inside actuator to its full extent noting the ease of movement.
- 5.4 From both full and half open positions slam the door closed, checking that it does not rebound and that the handle (and inside actuator if fitted) return to the correct position and the bolt slides freely into the engage position.
- 5.5 Record any abnormal wear of the lock, lock bolt, ram (double action) and the striking plate engaging surfaces.
- 5.6 On double action locks check that the spring loaded safety catch is in order and functions correctly. Measure and record the extension, see Appendix B. On single action locks check that the lock bolt engages with the safety recess.
- 5.7 On double action locks measure and record the engagement of the lock bolt with the safety catch, minimum 5mm, see Appendix B.
- 5.8 On single action locks check that the striking plate safety position recess is not worn and that the lock bolt correctly engages.
- 5.9 With the door open and the lock bolt engaged on the safety catch or recess, insert a bar having approximately 1 metre leverage between the lock and the striking plate above the bolt. Carefully apply pressure and attempt to force the door open. DO NOT apply sufficient force to damage the lock or striking plate.

5.10 With the door open release the lock and measure and record the length of the bolt fully extended and compare with the following. See also Appendix B.

Lock Drg. No.	Extension	
	mm	in
SC/DE/21626)	22.2	0.875
B1-A1-9015382)		
C-A1-1469)		
B1-A0-9002399)		
B1-S-90165127)		
C1-A1-335)		
B1-A0-9016664)	16.3	0.641
SC/ES/893)		

5.11 Check the lock bolt spring/s force using the testing device to BR Drg. No. TVE-AO-0030 see Appendix C. This should be used as follows:-

- 5.12.1 The device must be inserted into the striking plate and attached to the end of the bolt.
- 5.12.2 The bolt must be fully extended.
- 5.12.3 The gauge readings obtained must be multiplied by 3 and compared with the following:-

Lock Type	Drg. No.	Min. force to commence actuation		Min. force to complete actuation		Max. force to complete actuation	
		kgf	lbf	kgf	lbf	kgf	lbf
<u>Single Action</u>							
Inside and outside actuation	B1-A0-901664)	4.9	10.75	5.9	13	6.75	15
Outside actuation	SC/ES/893)						
	C-A1-335)						
<u>Double Action</u>							
Inside and outside actuation	B1-S-901657)	5.45	12	-		6.82	15
	SC/DE/21626-2)						
Outside actuation	SC/DE/21626-1)	6.75	15	-		13.5	30
	SC/DE/21626-11)						
	SC/DE/21626-15)						
	B1-A0-9015382)						
	C-A1-1469)						
	B1-A0-9002399	14.5	32	-		22.23	49

5.13 For doors having inside actuation check using the device to BR Drg. No. TSU-AO-9018312, see also Appendix D. The force required should be between 11.4 - 6.9 kgf (25 - 15 lbf).

6. EMERGENCY BODYSIDE DOOR EXAMINATION

6.1 Carry out checks paras. 5.1.1. - 5.1.5/5.1.7/5.5 - 5.12. In addition check the following:-

- 6.1.1 That the transparent cover over the emergency handle is intact (where fitted).
- 6.1.2 That, with the door closed, the emergency handle is in the correct position.
- 6.1.3 That, with the door closed, the indicator on the lock bolt is either aligned with the indentation on the lock case or is at the end of the slot nearest to the striking plate.

7. BENCH TESTING

7.1 Removed locks forwarded to the R.M. & E.E., see para 3.3, must be sent either by registered post, by hand or other traceable means, to the D.M. & E.E., Room 'TX', R.T.C., Derby for testing as follows:-

- 7.1.1 The lock bolt is compressed at a constant rate of 50mm/minute for 2mm of travel and held in this position for one minute.
- 7.1.2 Compression is then resumed at the same constant rate until 16mm of travel is reached and the bolt is again held in this position for one minute.
- 7.1.3 Continue compression at the same constant rate to 18mm of travel.
- 7.1.4 A continuous recording of the compressive forces exerted shall be made. The static and dynamic loads at 2mm and 16mm respectively shall be reported as well as the terminal load at 18mm. Any erratic mechanism movement shall be reported. On double acting locks the distance of traverse at which the prop mechanism is activated shall also be reported.

REPORTING FORM

EXAMINER'S NAME: LOCATION: SIGNATURE:

1. Initial Examination. (This MUST be completed by the person who attended the incident to examine the door as required by Clause 2)

1.1 Date: 1.2 Time: 1.3 Vehicle No.:

1.4 Train: 1.5 Location:

1.6 Indicate on sketch the door position, direction of travel and of door opening:

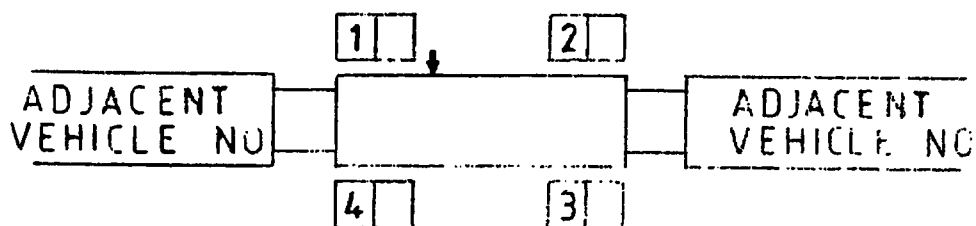

1.7 Give details of door condition and action taken:

2. Bodyside Door Examination

2.1 Date door last received scheduled examination and details of work carried out:

Note Against each of the following items place a tick if the condition is correct. If not applicable mark N/A. Otherwise give a full description of the defect and if necessary append a sketch. The numbers in brackets refer to the relevant paras. in Chapters 5 and 6.

2.2 Stepboard (5.1.1)

2.3 Check strap (5.1.2)

2.4 Limit control (5.1.2)

2.5 Damage to bodyside (5.1.3)

2.6 Hinges (5.1.4)

- 2.7 Guide plate/support plate (5.1.5)
- 2.8 Lock fastenings (5.1.6)
- 2.9 Striking plate fastenings (5.1.6)
- 2.10 Lock/bolt/striking plate alignment (5.1.7)
- 2.11 Droplight lock (5.1.8)
- 2.12 Droplight movement (5.1.8)
- 2.13 Door edge clearance (5.1.9)
- 2.14 Handle security (5.2)
- 2.15 Rose plate security (5.2)
- 2.16 Outside handle action (5.3)
- 2.17 Inside actuation action (5.3)
- 2.18 Slam test (5.4)
- 2.19 Abnormal wear (5.5)
- 2.20 Safety catch action (5.6)
- 2.21 Safety catch extension (5.6)
- 2.22 Lock bolt/safety catch engagement (5.7)
- 2.23 Safety recess condition (5.8)
- 2.24 Forcing test 1 (5.9)
- 2.25 Forcing test 2 (5.10.2)
- 2.26 Forcing test 3 (5.10.4)
- 2.27 Lock bolt extension (5.11)
- 2.28 Force to commence actuation (5.12.3)
- 2.29 Force to complete actuation (5.12.3)
- 2.30 Force for inside actuation (5.13)
- 2.31 Emergency handle cover (6.1.1)
- 2.32 Emergency handle position (6.1.2)
- 2.33 Indicator alignment (6.1.3)

EXAMINER'S SIGNATURE:

1. SAFETY CATCH ENGAGEMENT

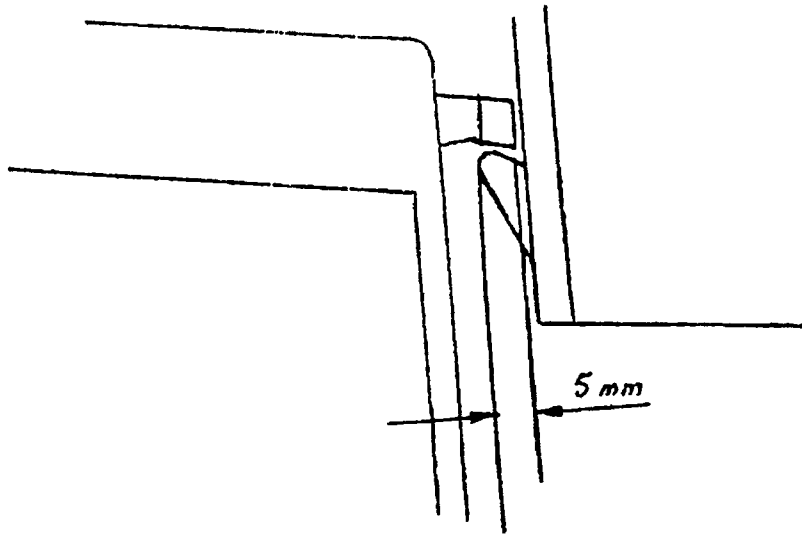

2. LENGTH OF LOCK BOLT

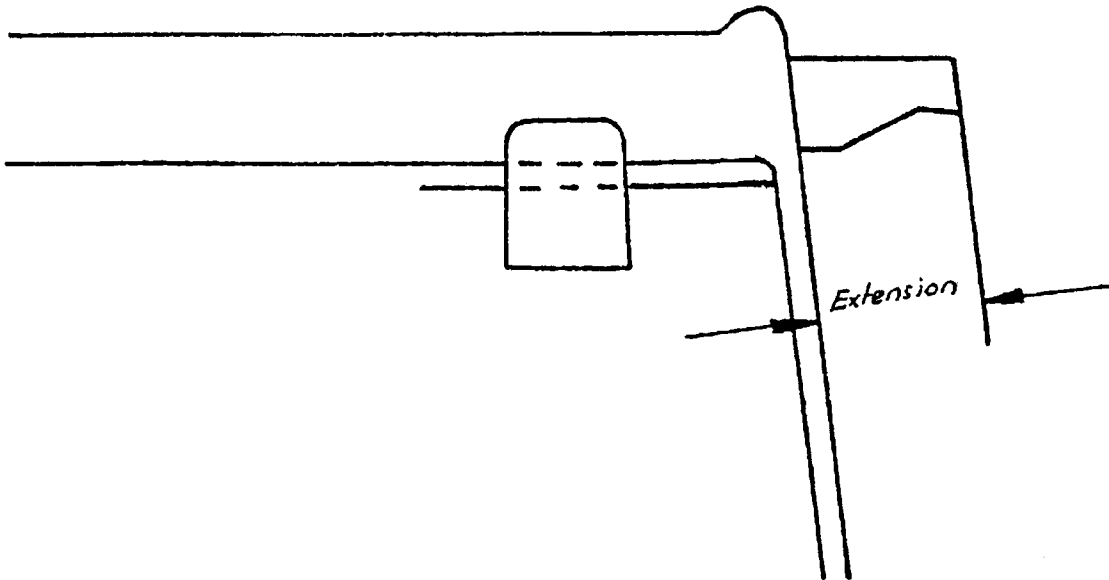

USE OF LOCK BOLT FORCE TESTING DEVICE

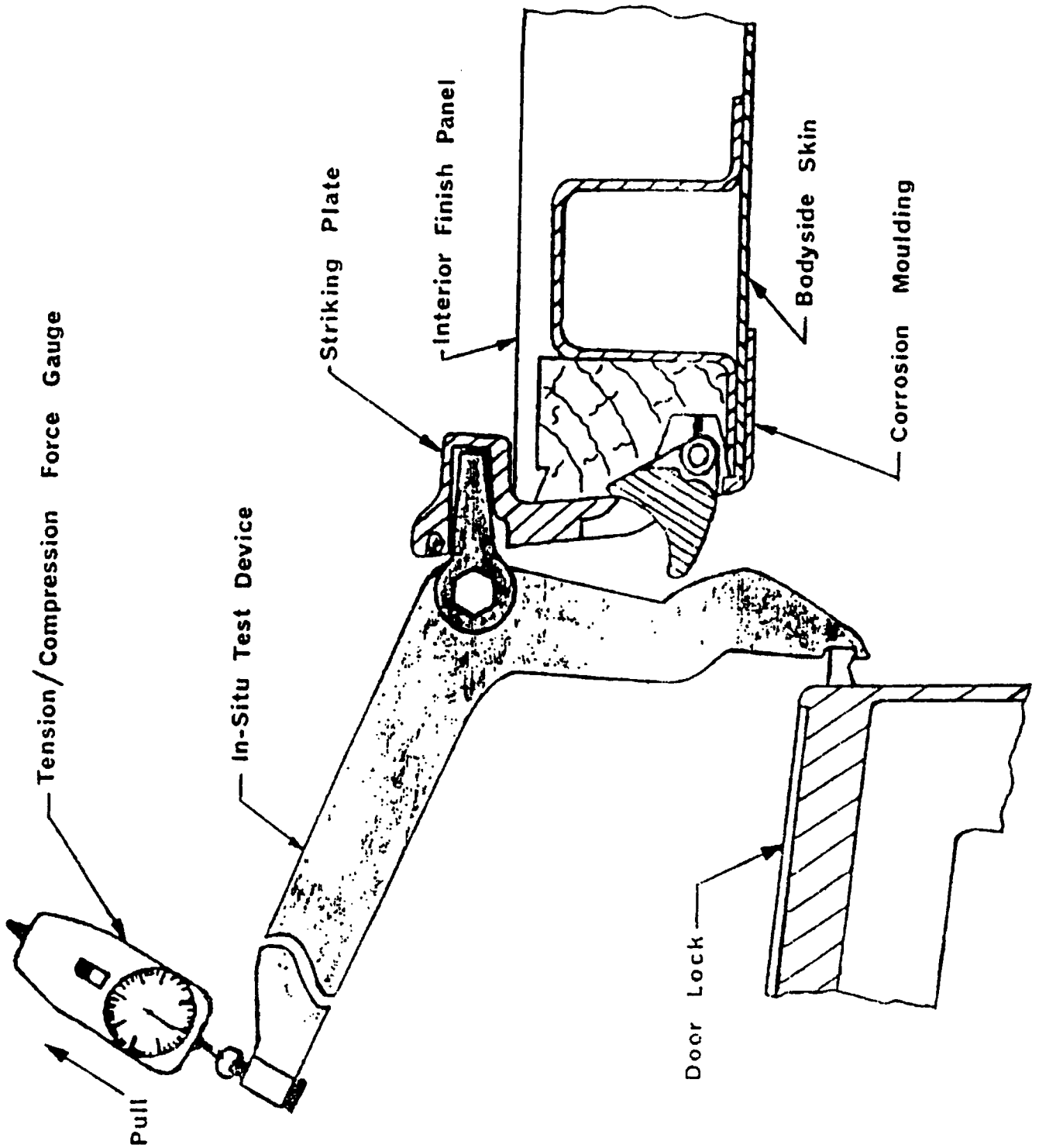

April 1986

USE OF INSIDE ACTUATION FORCE TESTING DEVICE

The handle must be turned clockwise until the inside actuation just starts to operate. At this point the reading is taken.

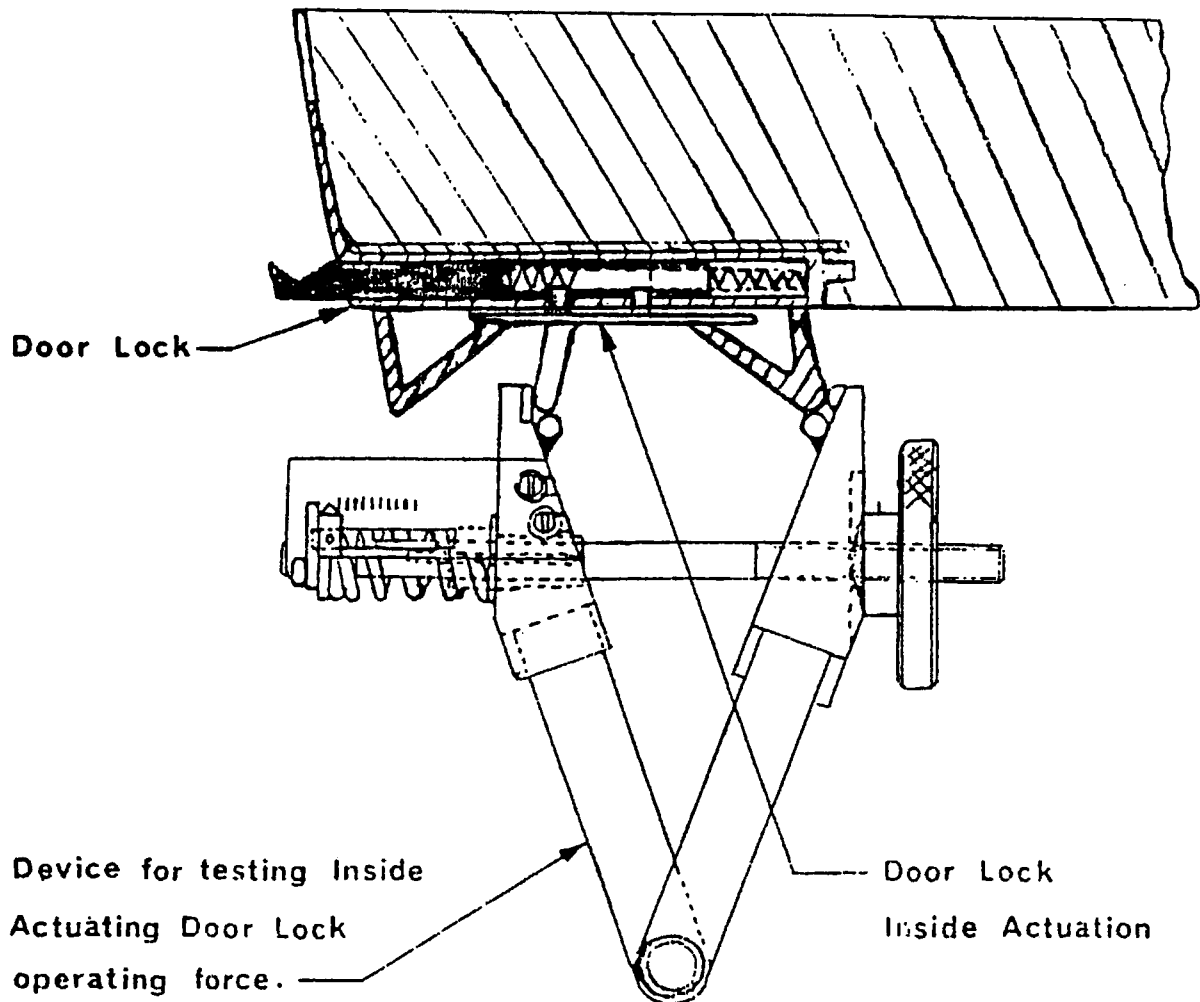

LOCK IDENTIFICATION

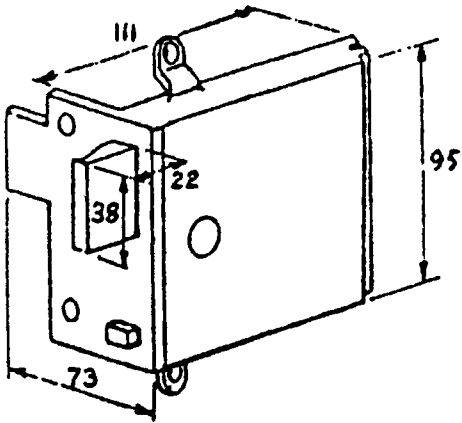

Used on Mks I, II & IIa
Drg. No. B1-A0-9015382

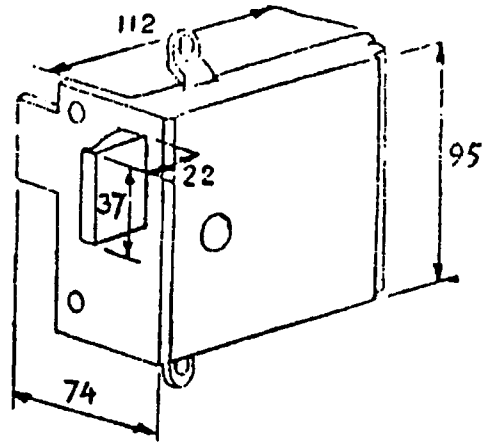

Used on Mk IIb & IIc
Drg. No. C-A1-335

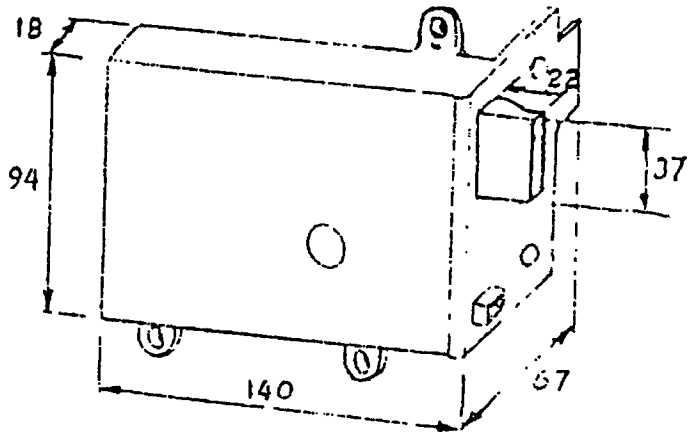

Used on Mk III
Drg. No. B1-A0-9002399

LOCK IDENTIFICATION

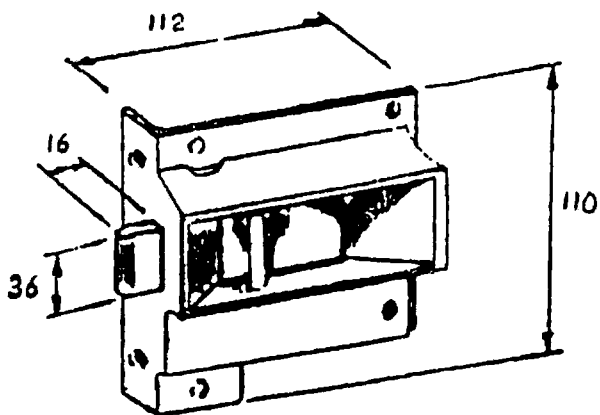

Used on SR EMU's & DEMU's
Drg. No. B1-A0-9016664

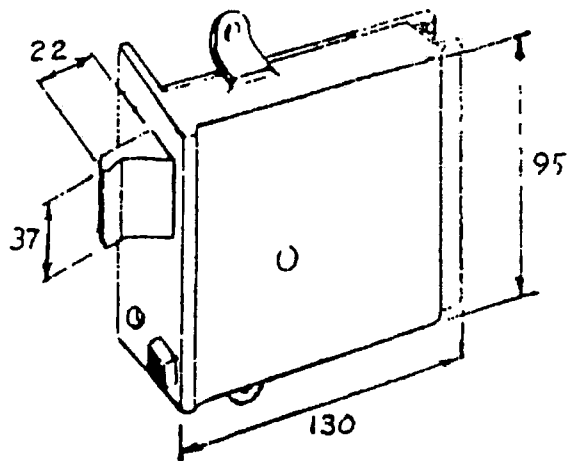

Used on Classes 120, 123, 124 & 119 DMU's
Drg. No. SC/DE/21626

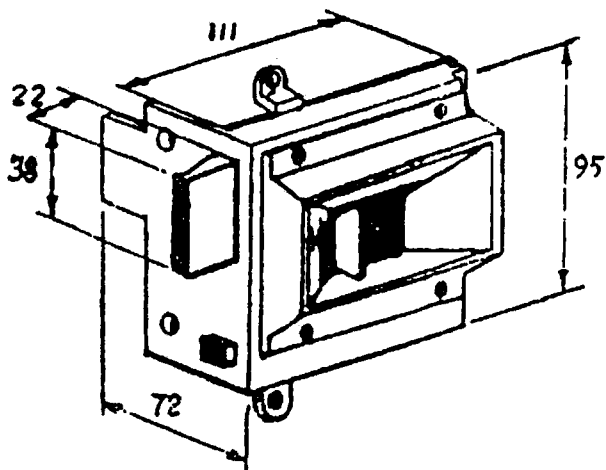

Used on all other EMU's & DMU's
Drg. No. B1-S-9016517