

**ASSEMBLY OF THE
TYPE R14 GEARBOX**

RAILCAR.CO.UK

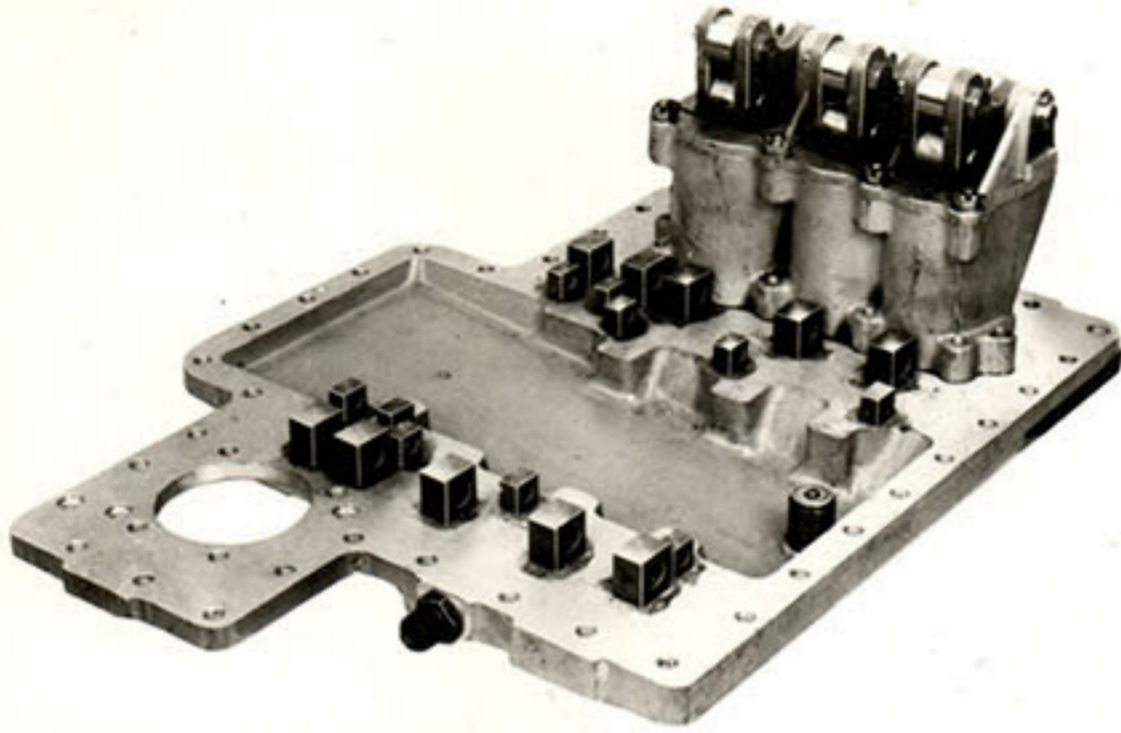

SELF-CHANGING GEARS LTD.



1. CYLINDER BLOCK SHOWN FITTED TO BASE PLATE WITH EYEBOLTS IN POSITION.



2. THE HOOKS AND

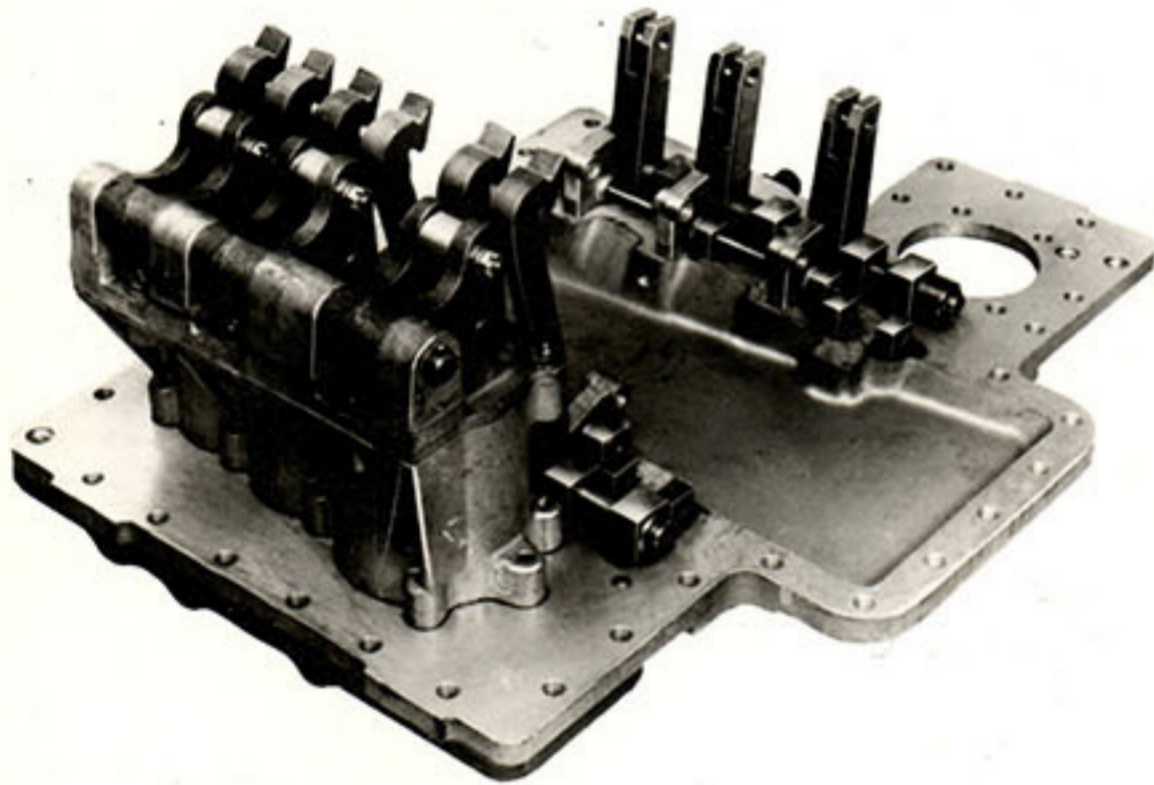

3. FOLLOWED BY THE RIGHT HAND CENTRALISERS AND BAND BRAKES.



4. MET

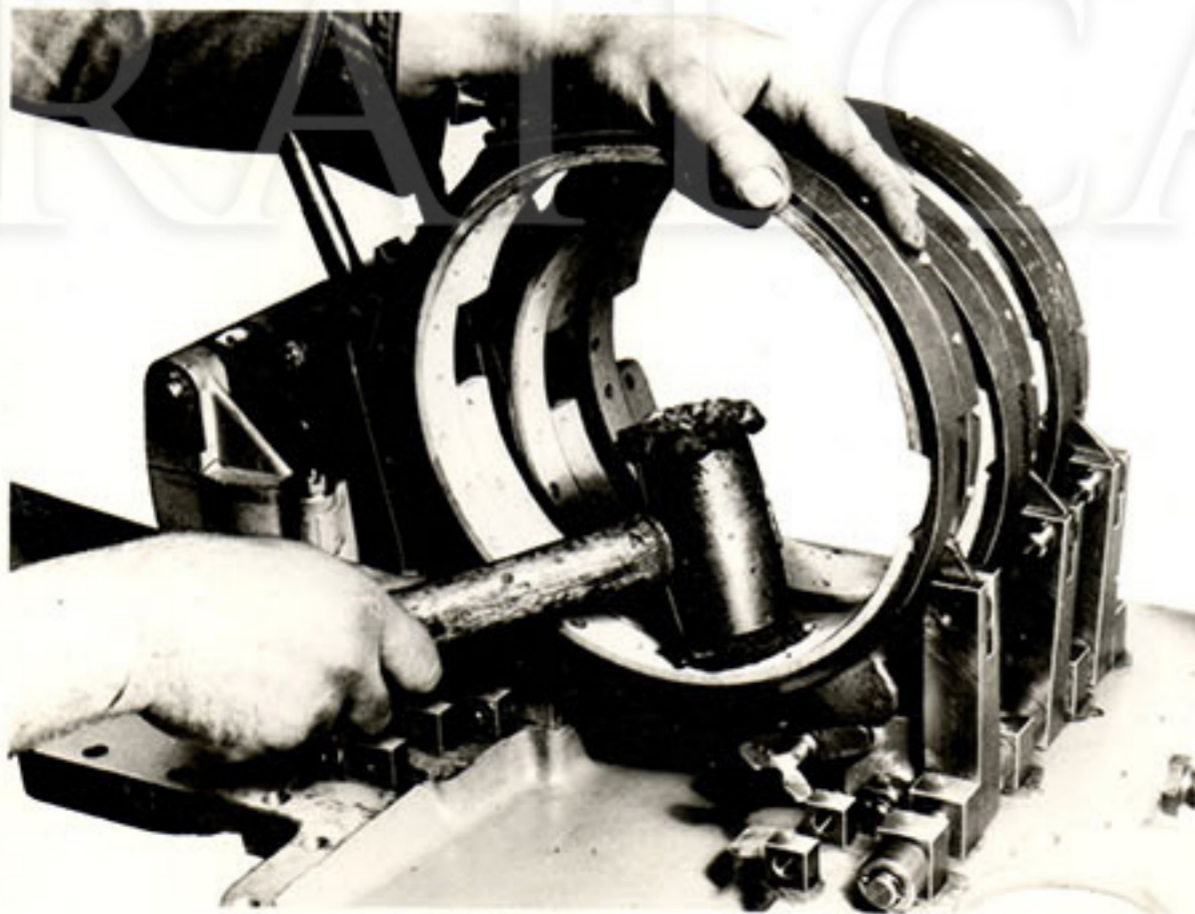

5. FIT THE BRAKE BANDS.



6. THE AUT

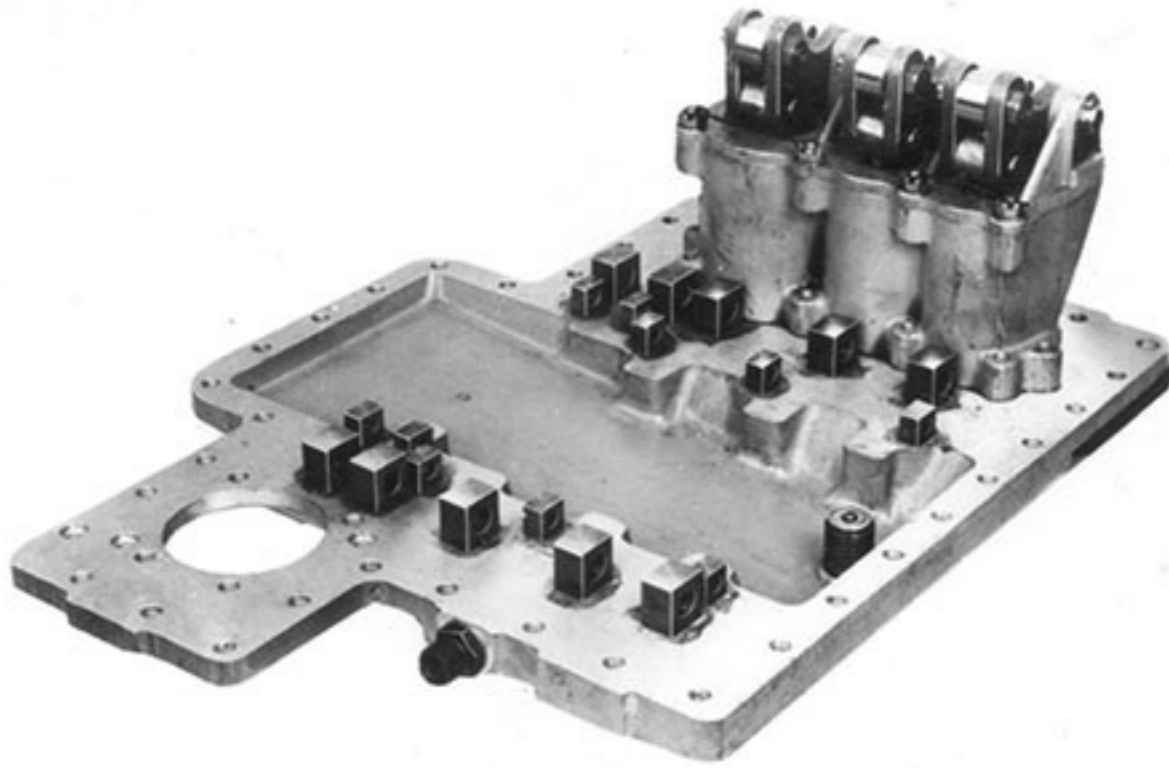

1. CYLINDER BLOCK SHOWN FITTED TO BASE PLATE WITH EYEBOLTS IN POSITION.

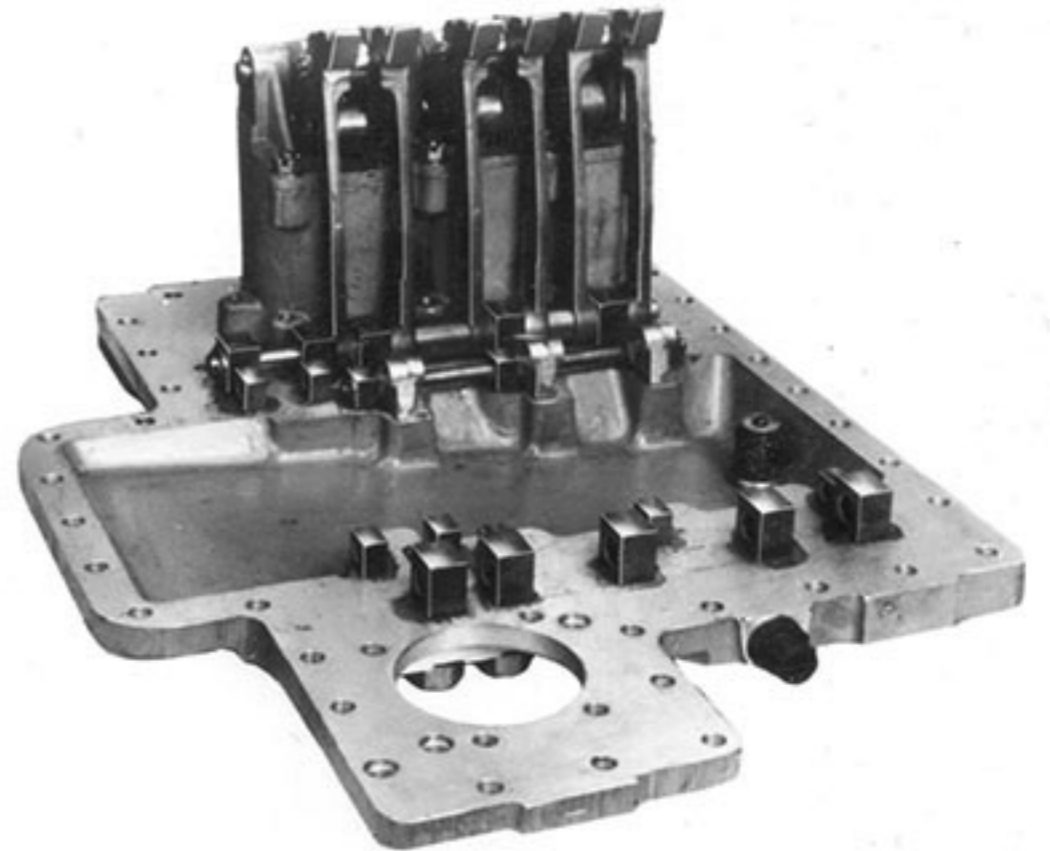

2. THE HOOKS AND LEFT HAND CENTRALISERS ARE THEN POSITIONED.

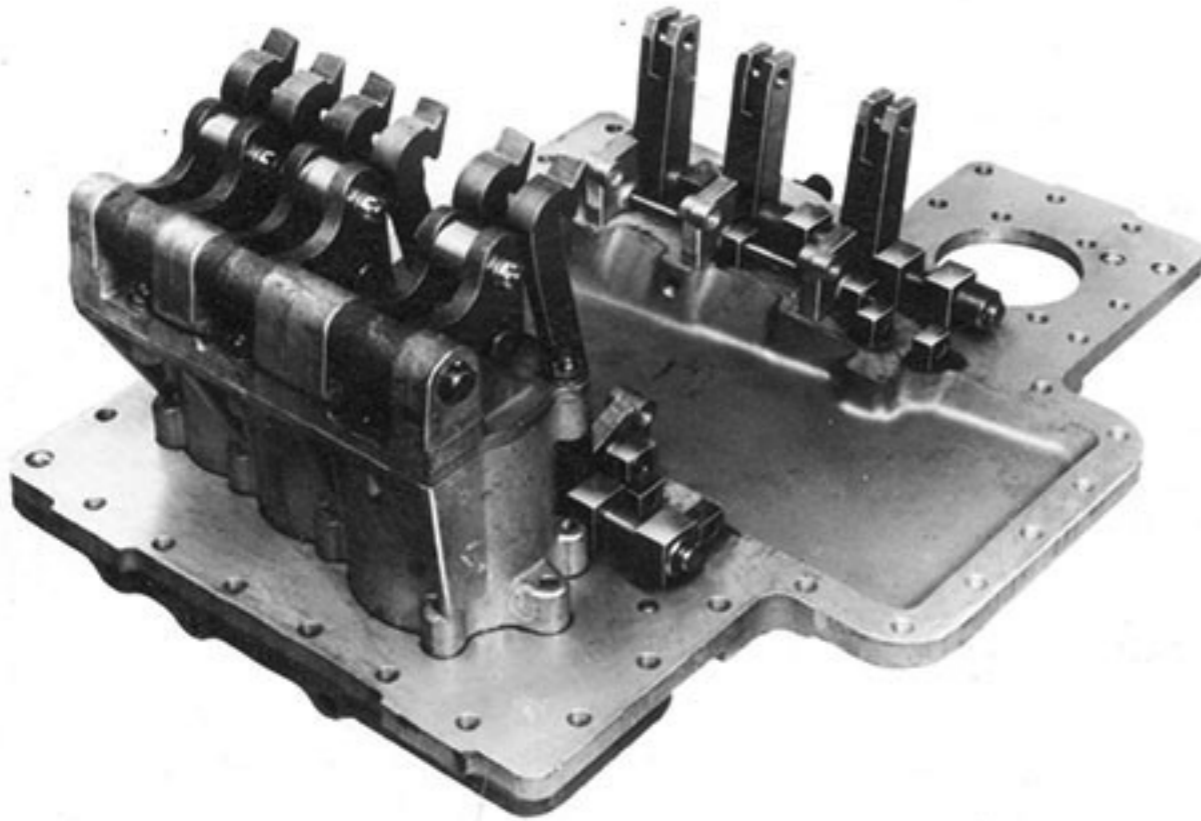

3. FOLLOWED BY THE RIGHT HAND CENTRALISERS AND BAND BRAKES.

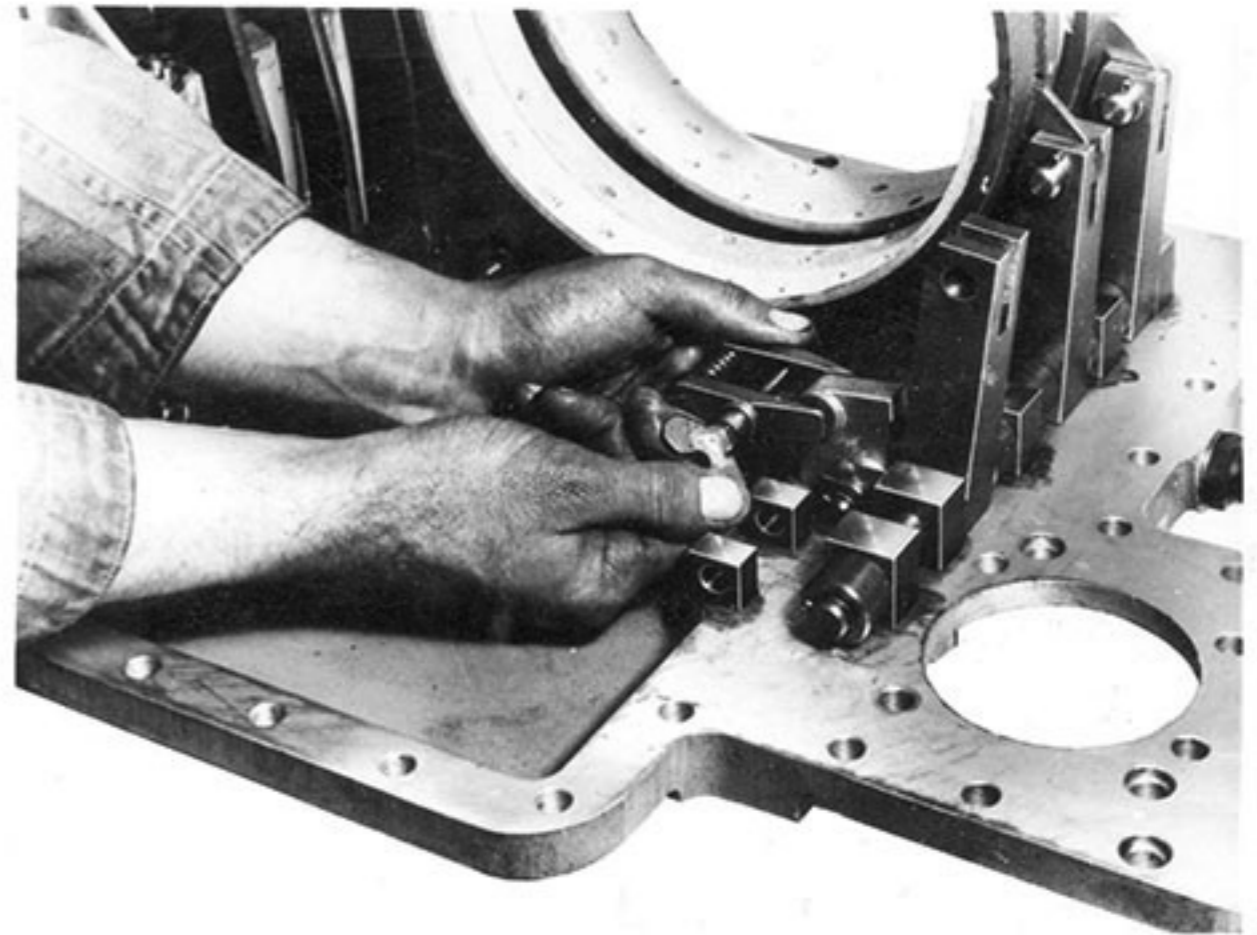

4. METHOD OF CLAMPING CENTRALISER SPRINGS.

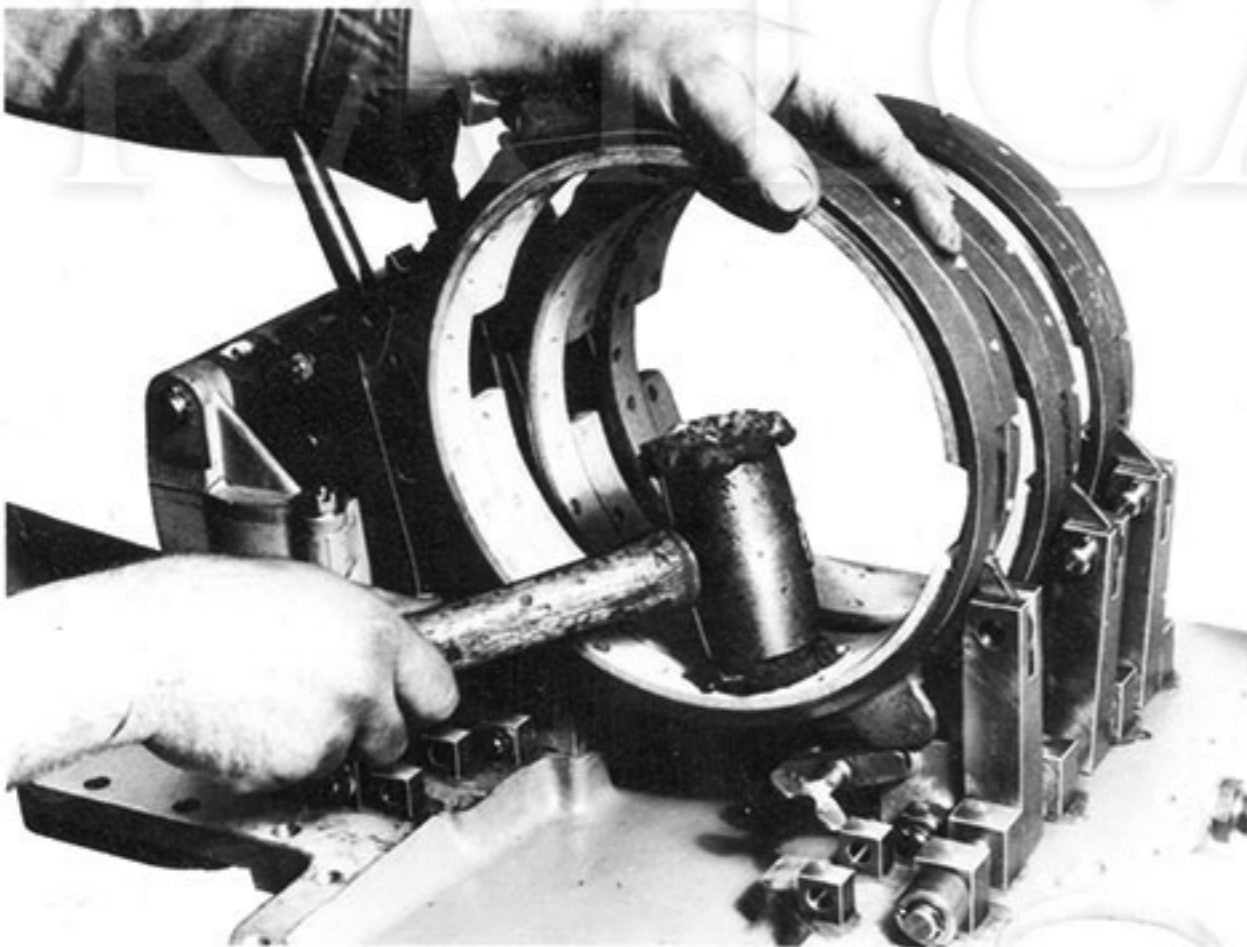

5. FIT THE BRAKE BANDS.

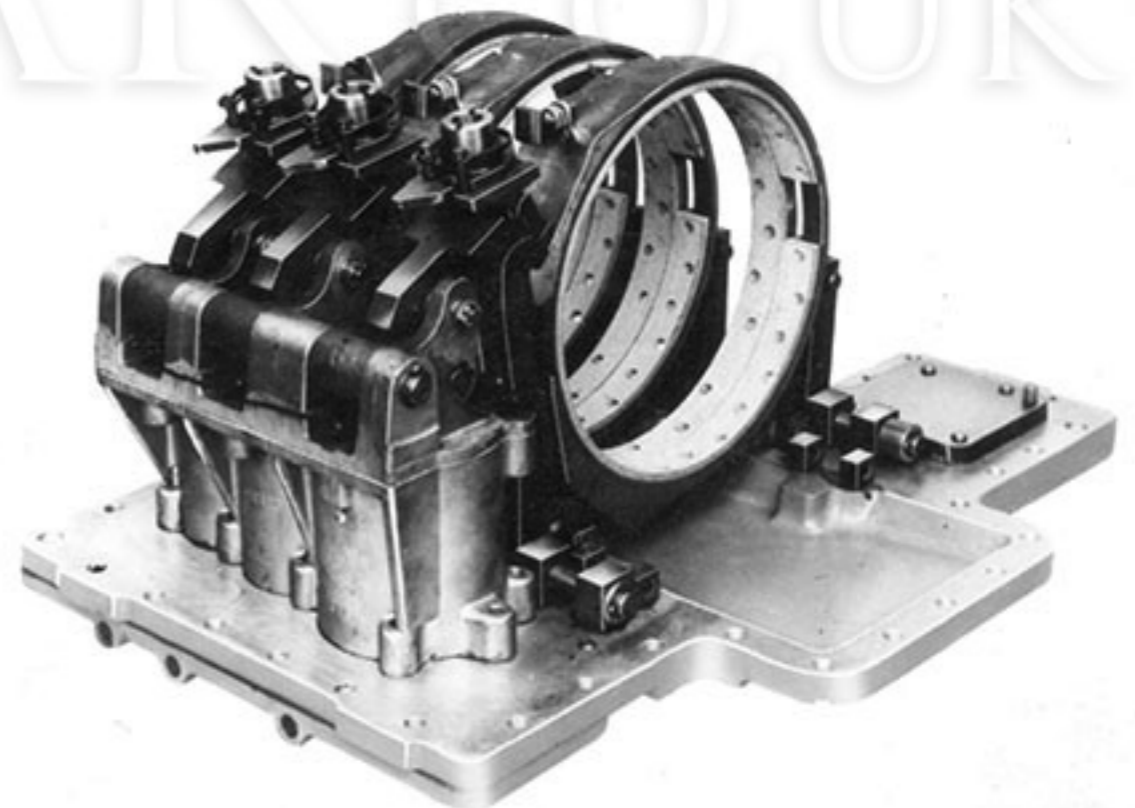

6. THE AUTOMATIC ADJUSTERS ARE THEN FITTED.

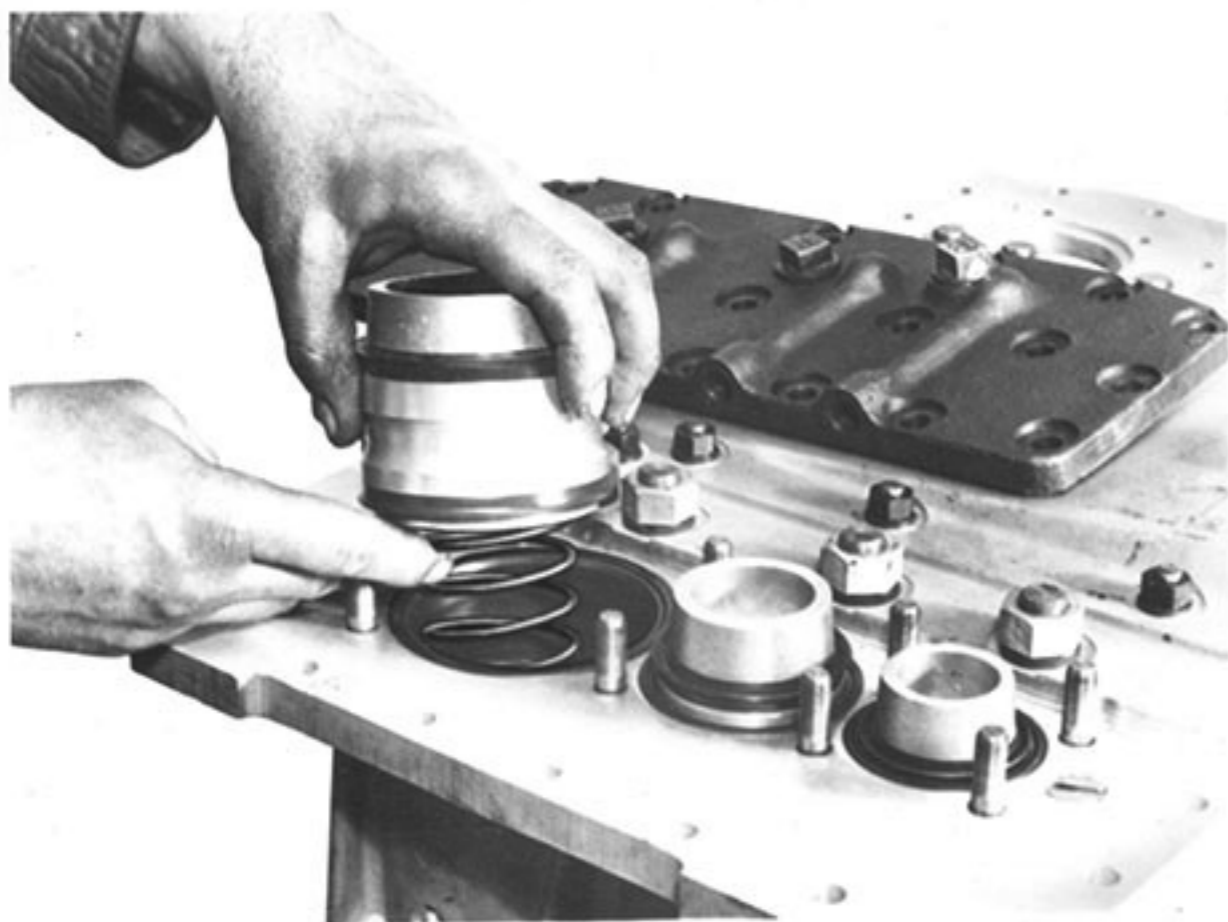

7. WITH BASE PLATE INVERTED, FIT THE PISTONS.

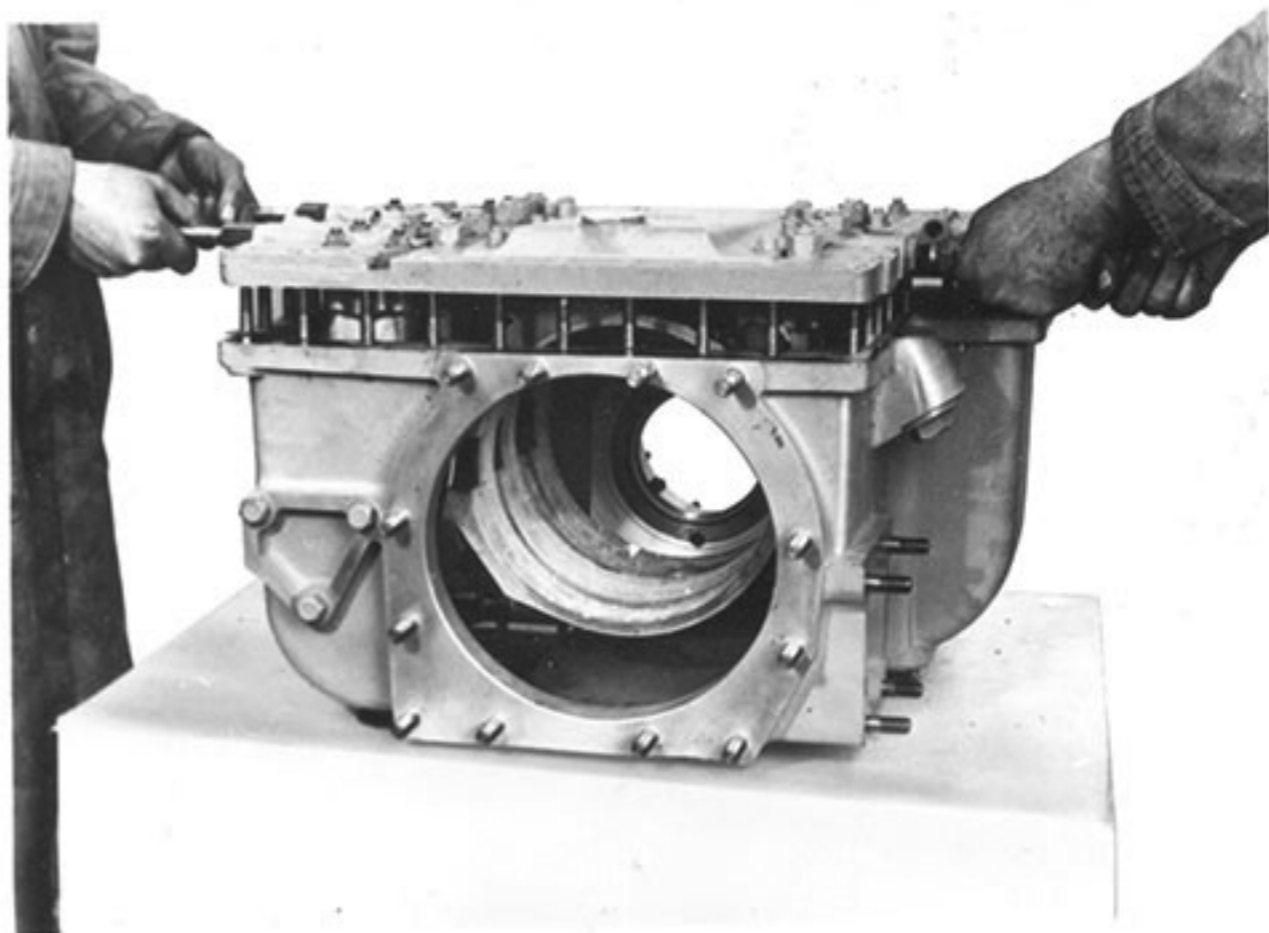

8. LOWER THE BASE ONTO THE UPTURNED GEARCASE, POSITIONING THE GASKET.

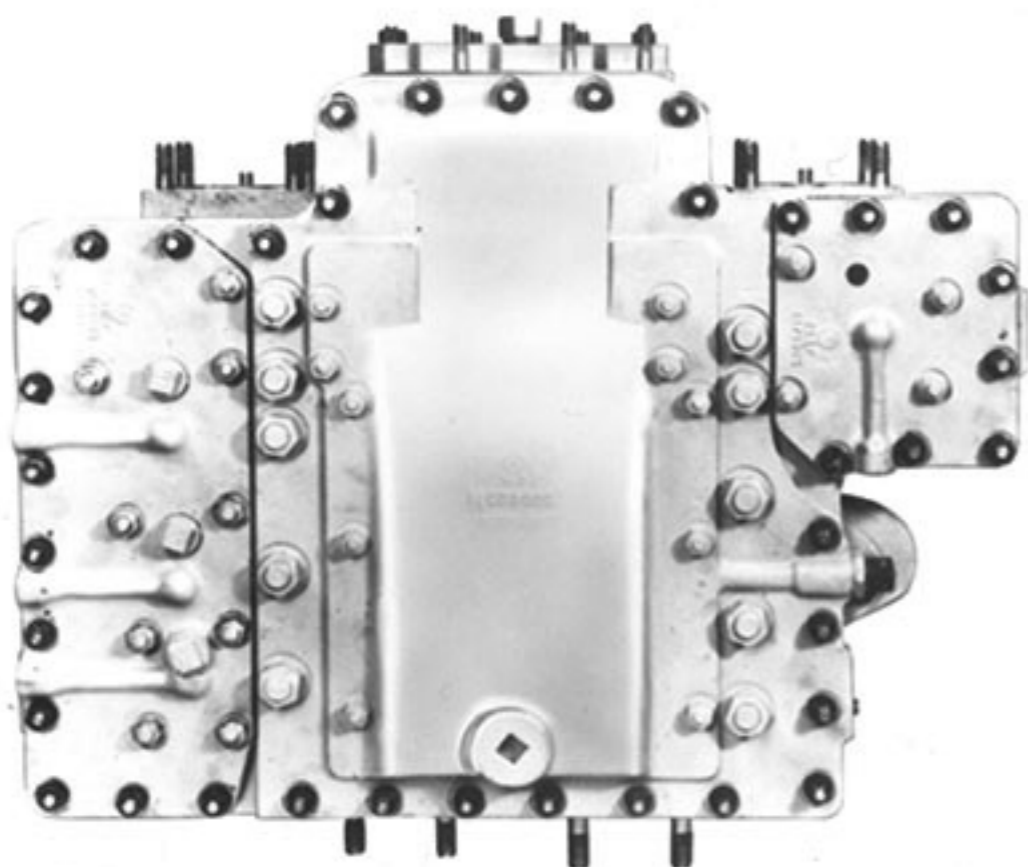

9. VIEW OF THE PLATE, BOLTED IN POSITION.

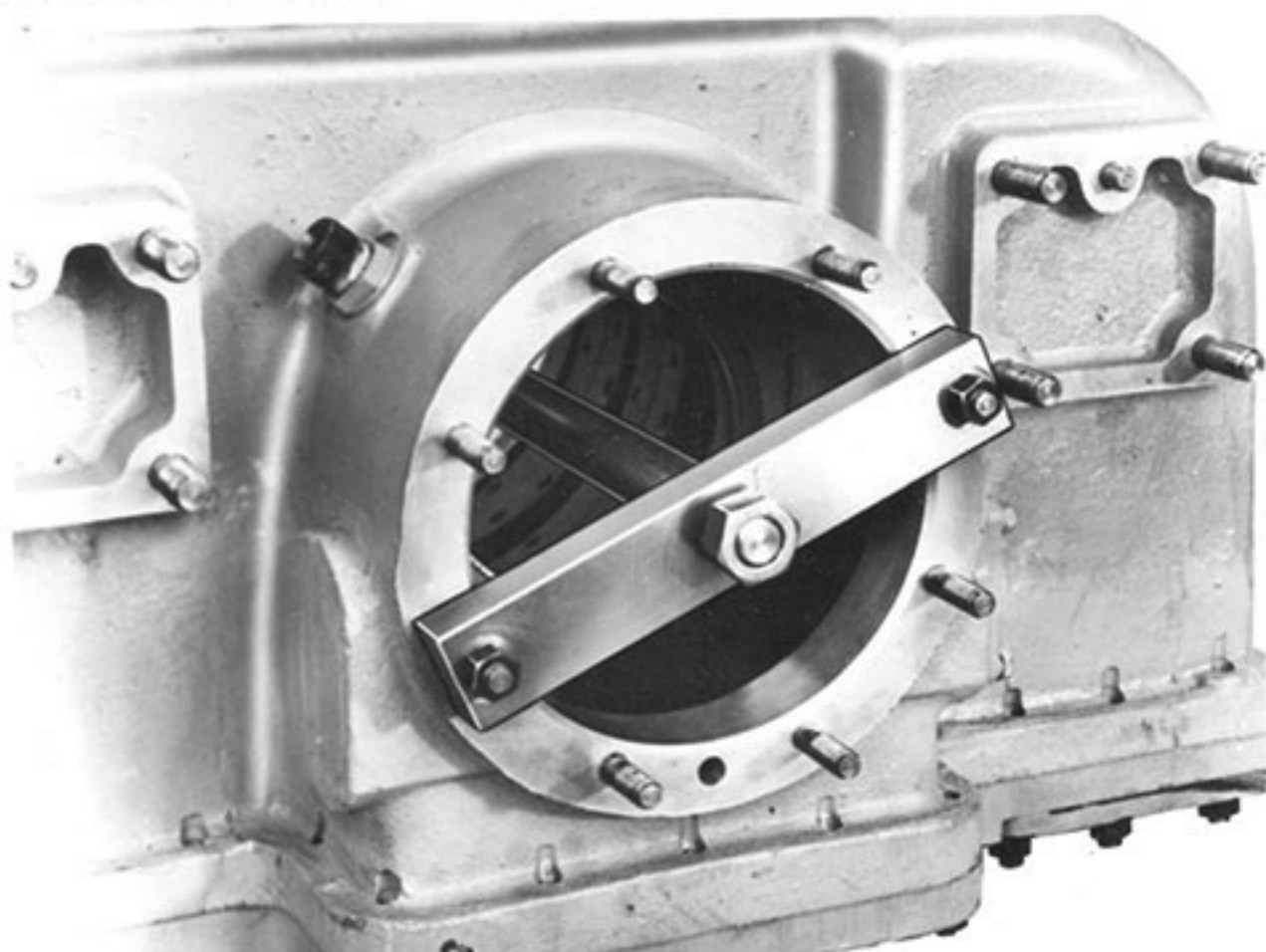

10. FIT THE MEASURING ROD IN GEARCASE.



11. THEN MEASURE THE LENGTH OF GEARCASE WITH FEELERS.

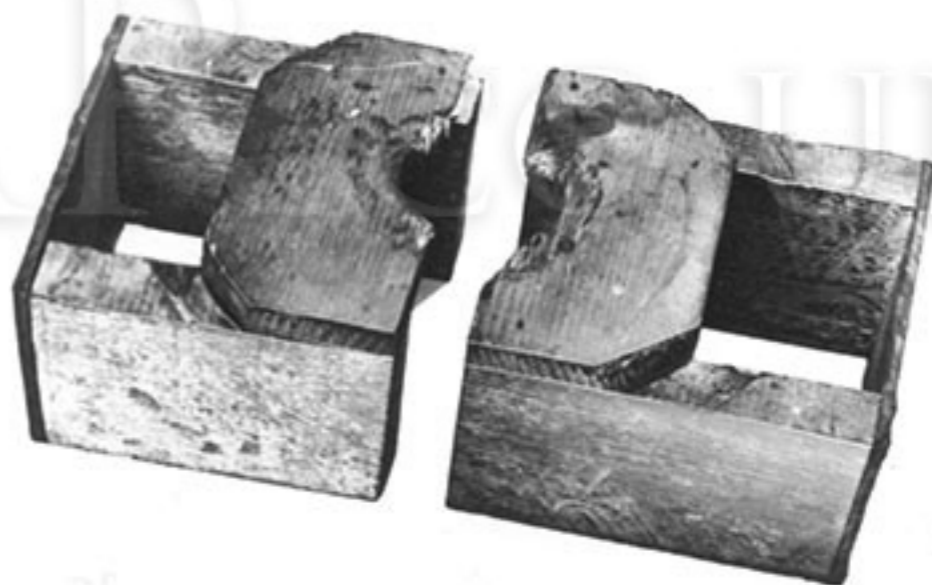

12. THE STAND AND CLAMP FOR RUNNING GEAR.



1. APPARATUS USED FOR MEASURING LENGTH OF GEARCASE AND RUNNING GEAR.

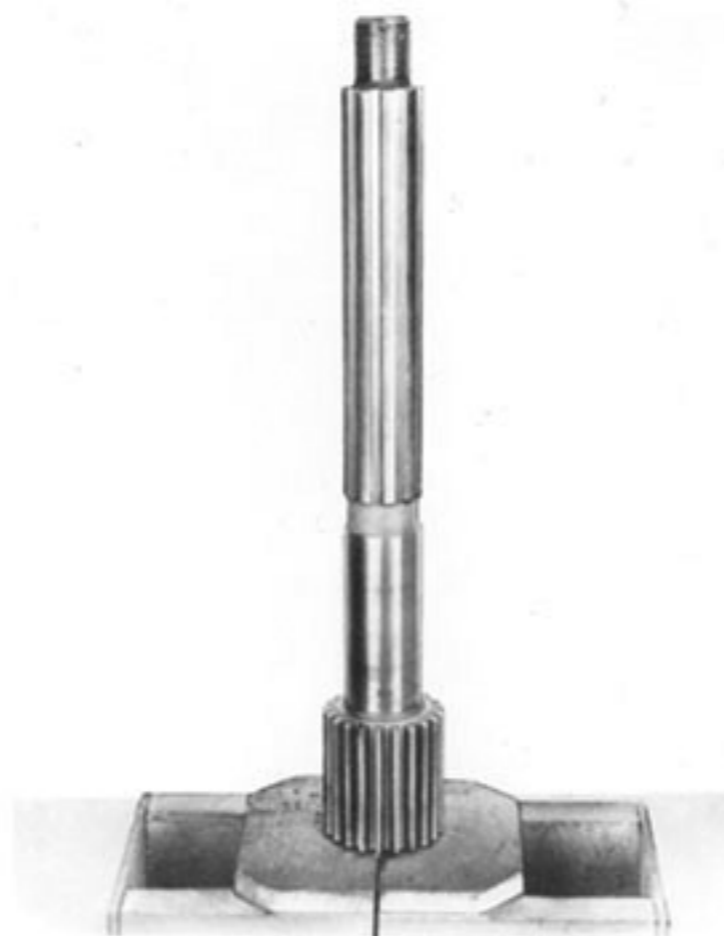

14. THE INPUT SHAFT IS PLACED ON THE STAND.



15. 1ST. SPEED DRUM IS THEN POSITIONED AND BUSH IS FITTED.



16. FIT THE 2ND. SPEED DRUM - FOLLOWED BY BUSH.



17. FIT THE OTHER BUSH.

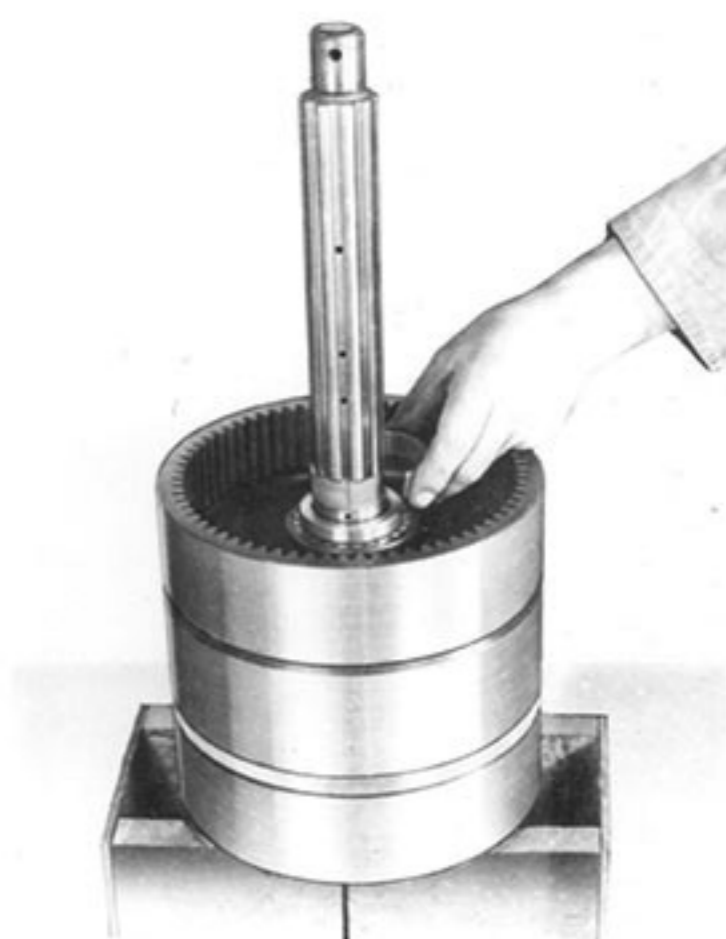

18. 3RD. SPEED DRUM POSITIONED, FOLLOWED AND BUSH IS AND SPLIT RING.



19. THE CLUTCH INNER MEMBER IS FITTED.



20. FOLLOWED BY THE INNER AND OUTER CLUTCH MEMBER.

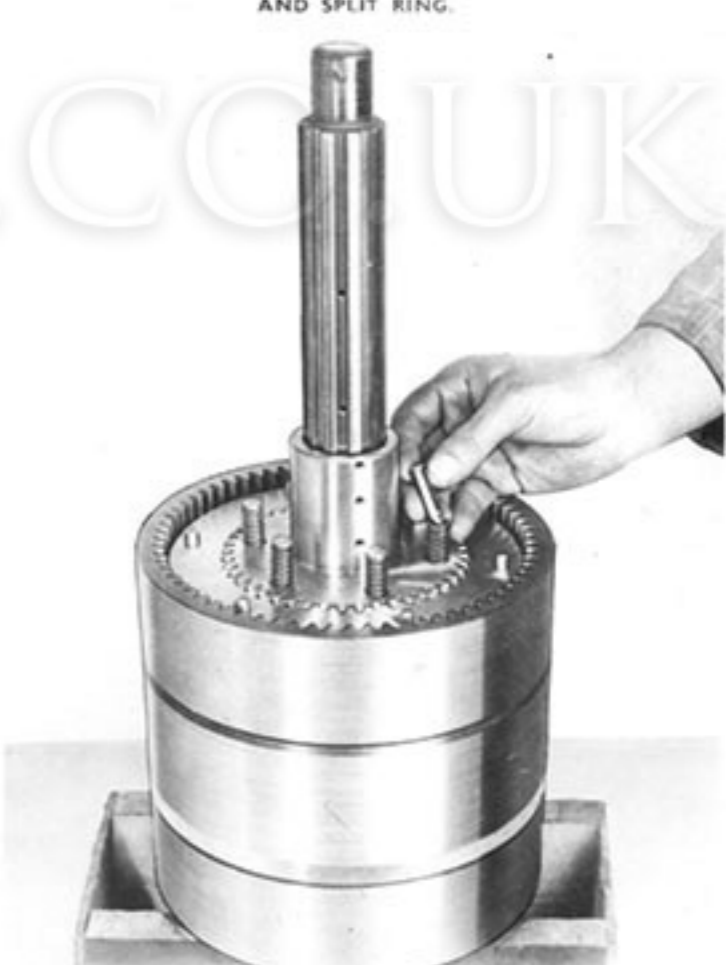

21. CLUTCH SPRINGS AND PEGS ARE THEN FITTED.

RAILCAR.CO.UK



22. THE CLAMP IS FITTED TO THE RUNNING GEAR AND THE TRUNNION RING ASSEMBLY IS FITTED.



23. THE SLEEVE IS FITTED.

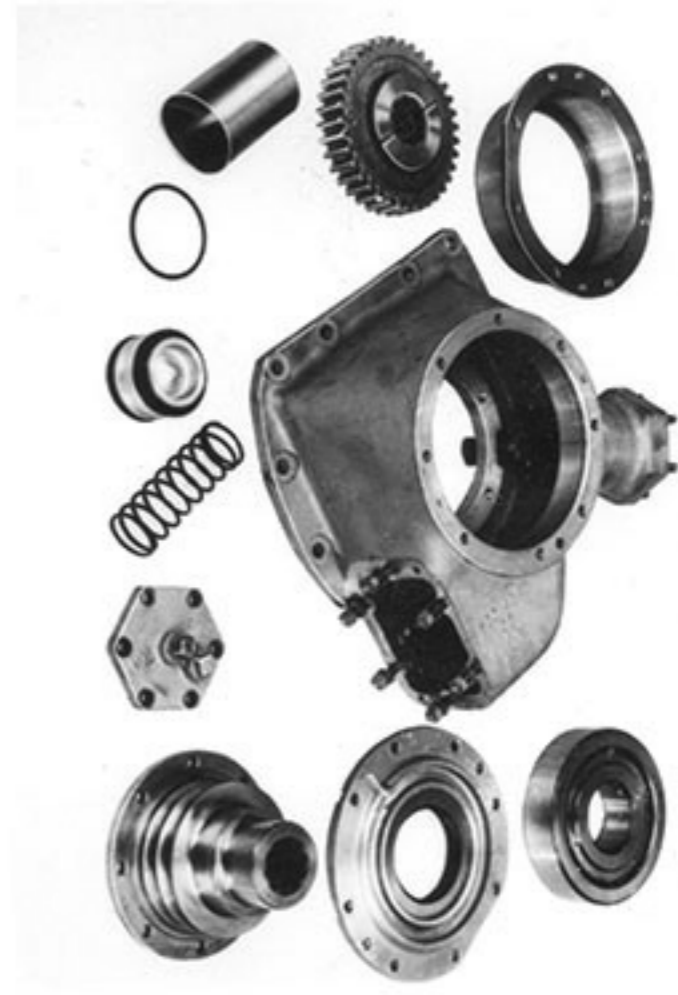

24. PARTS COMPRISING THE FRONT COVER.



25. FIT THE ASSEMBLED FRONT COVER TO THE RUNNING GEAR.



26. TIGHTEN THE INPUT END NUT.

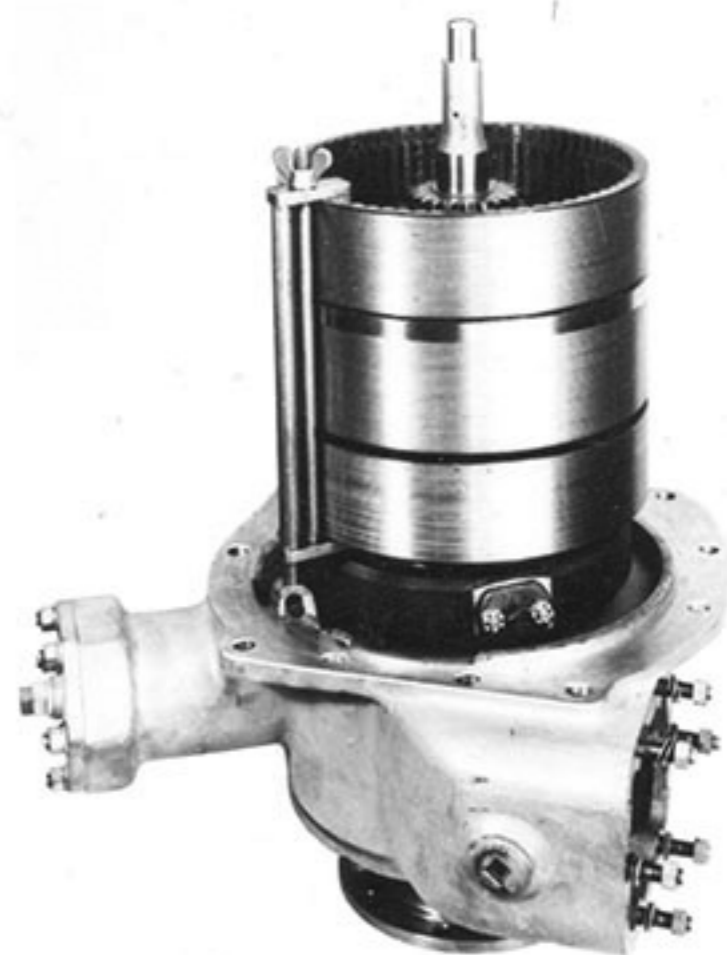

27. THE RUNNING GEAR IS THEN INVERTED.



28. THE CLAMP IS REMOVED AND THE ADJUSTER WASHER IS FITTED.



29. THEN FIT THE OUTPUT SHAFT.



30. FIT THE BEARING COLLAR AND THE OIL MUFF COLLAR.

RAYLOR.CO.UK



31. MEASURE THE LENGTH OF THE RUNNING GEAR.

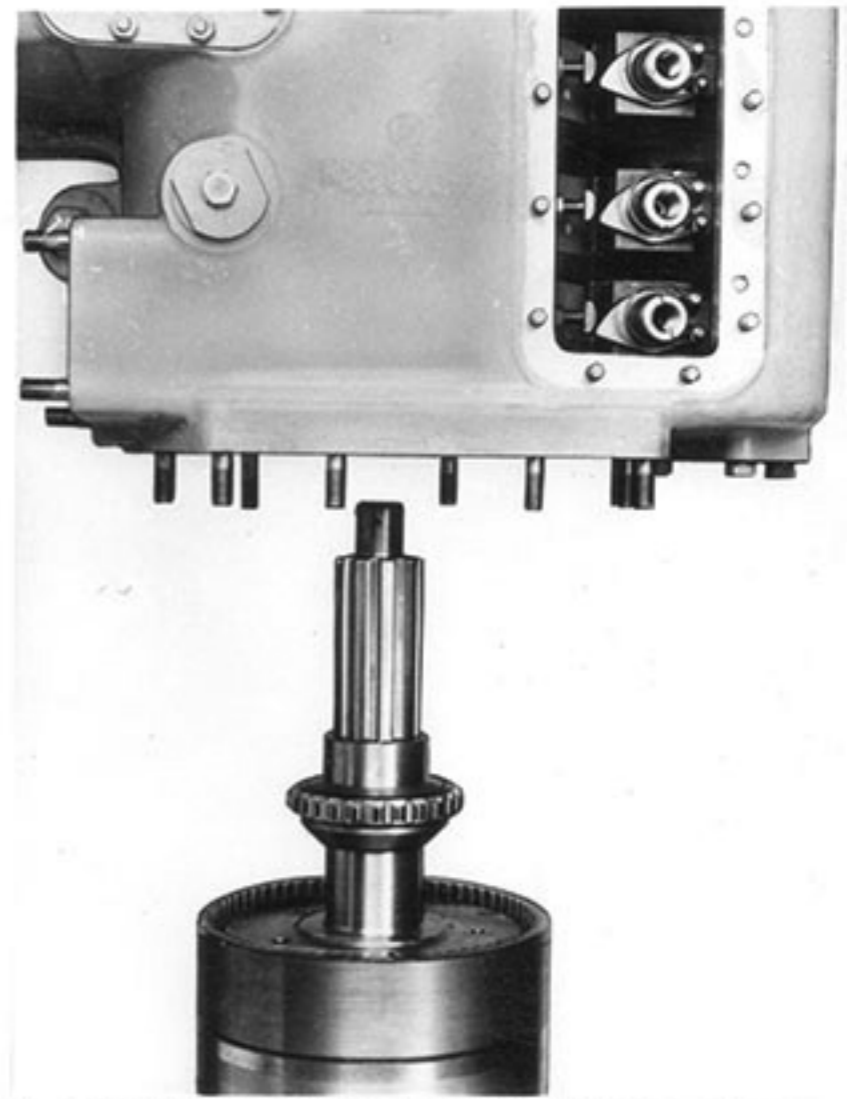

32. LOWER THE GEARCASE OVER THE RUNNING GEAR AFTER THE ROLLER BEARING IS FITTED.

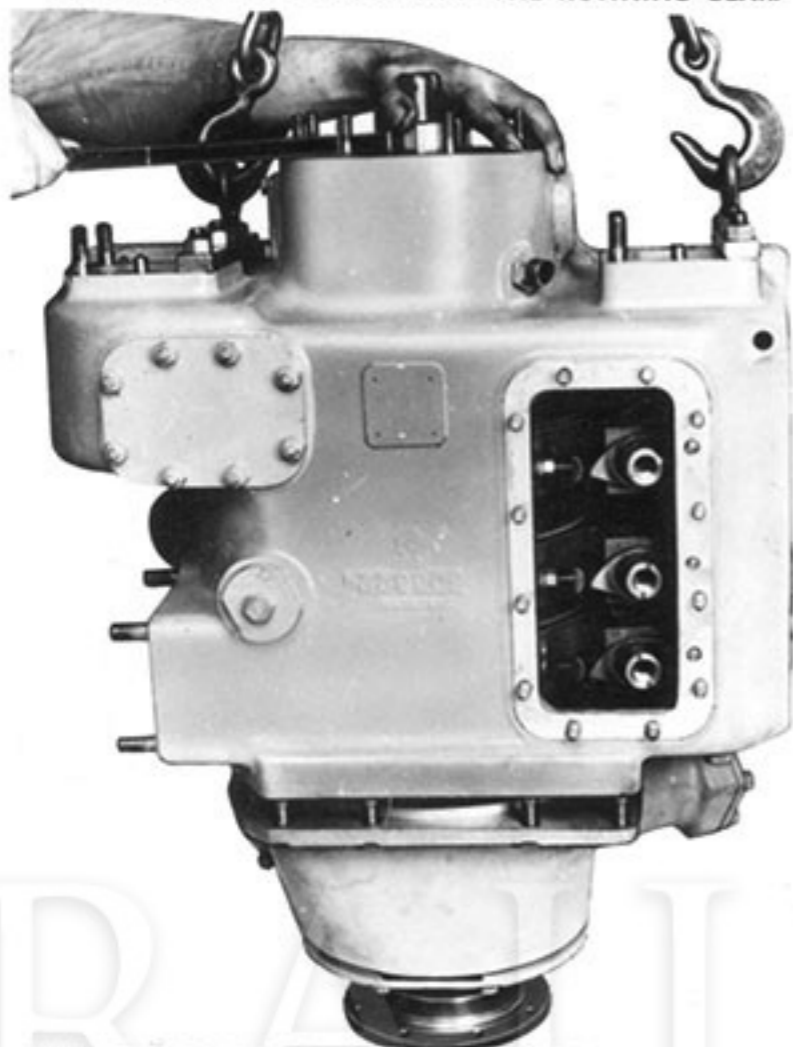

33. WITH THE GEARCASE NEARLY IN POSITION THE INNER RACE OF THE ROLLER BEARING IS MANIPULATED INTO THE OUTER RACE.

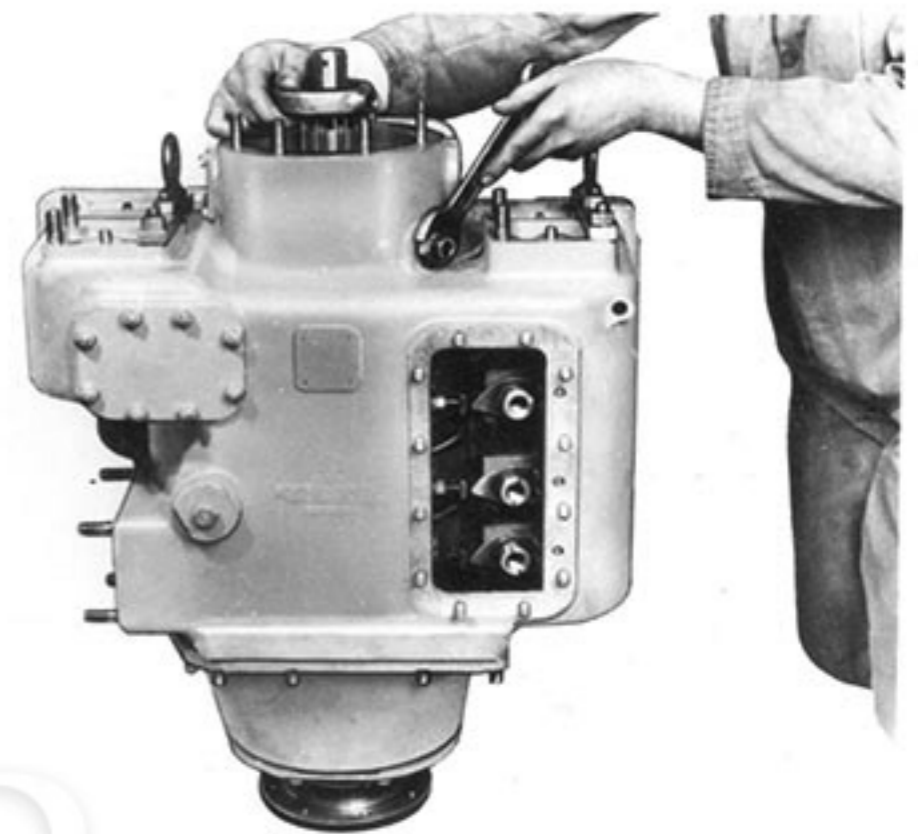

34. SECURE THE FRONT COVER TO THE GEARCASE BY FITTING NUTS TO STUDS, THEN POSITION THE OIL MUFF.

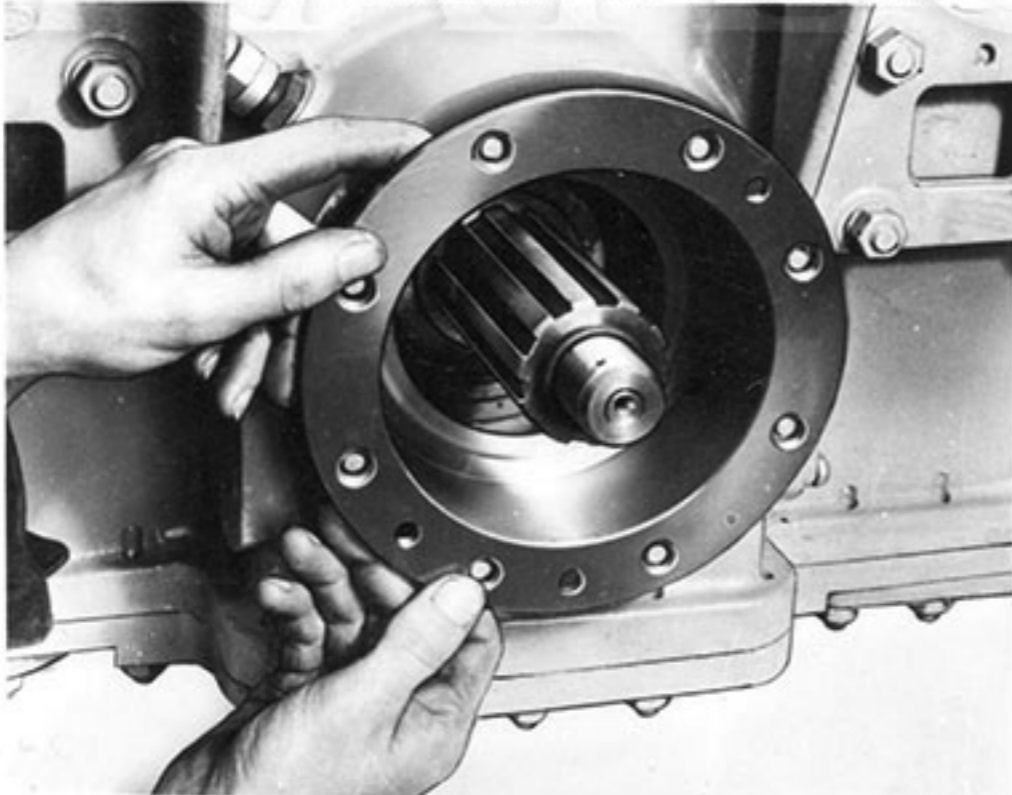

35. THE OUTPUT BEARING HOUSING IS FITTED.

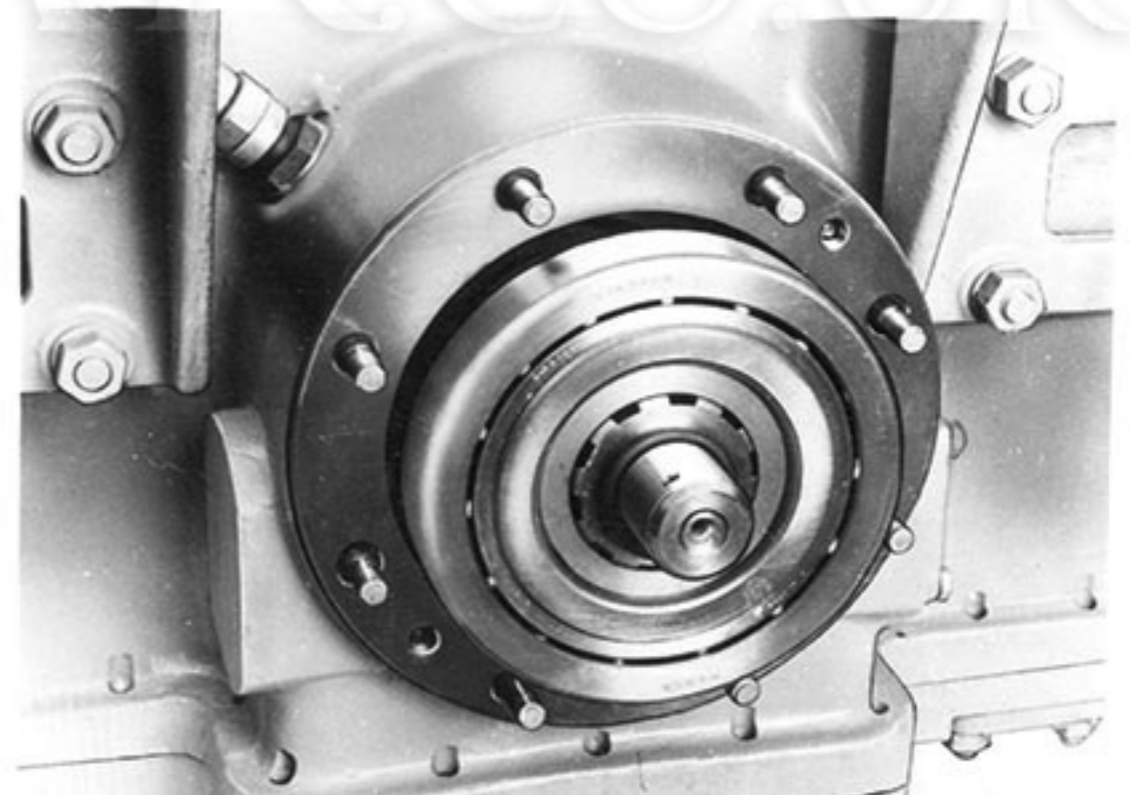

36. THE THRUST BEARING IS NOW POSITIONED IN THE HOUSING.

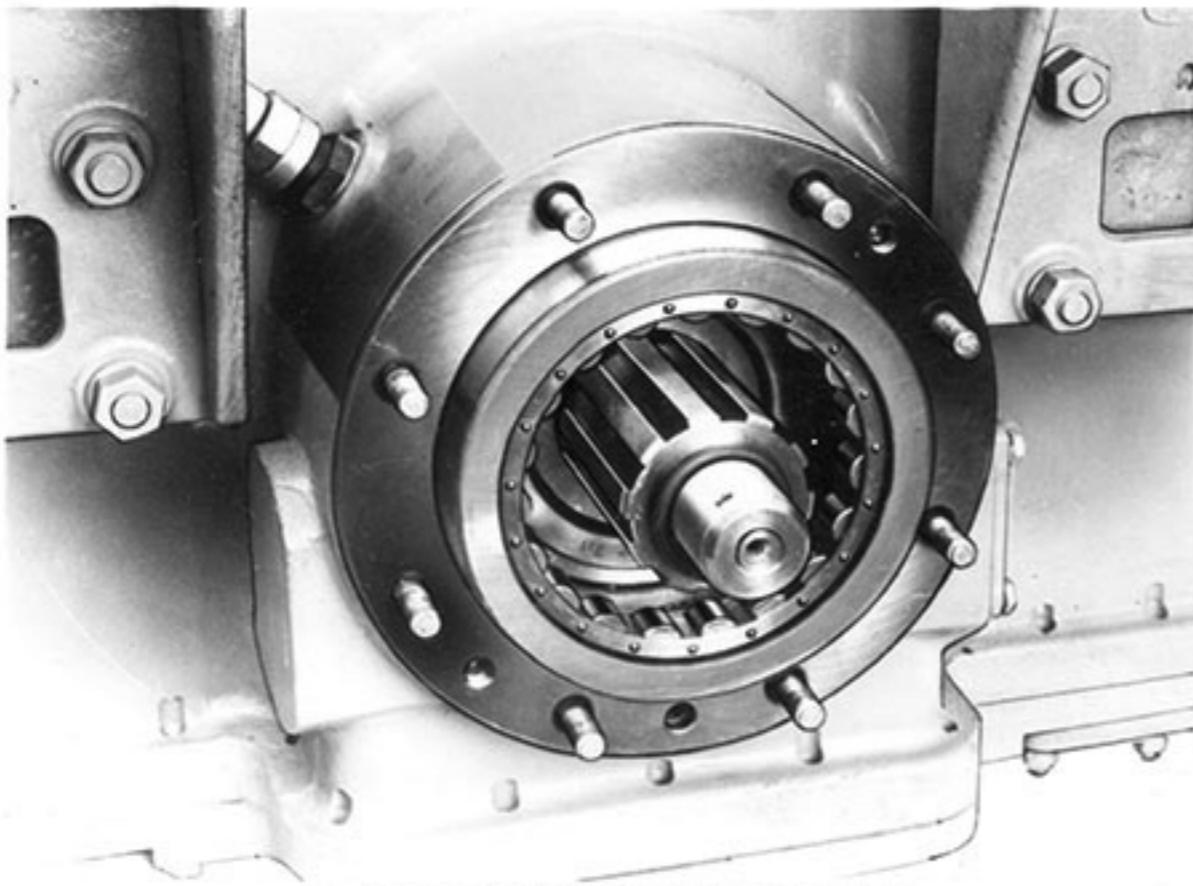

37. FOLLOWED BY THE ROLLER BEARING.

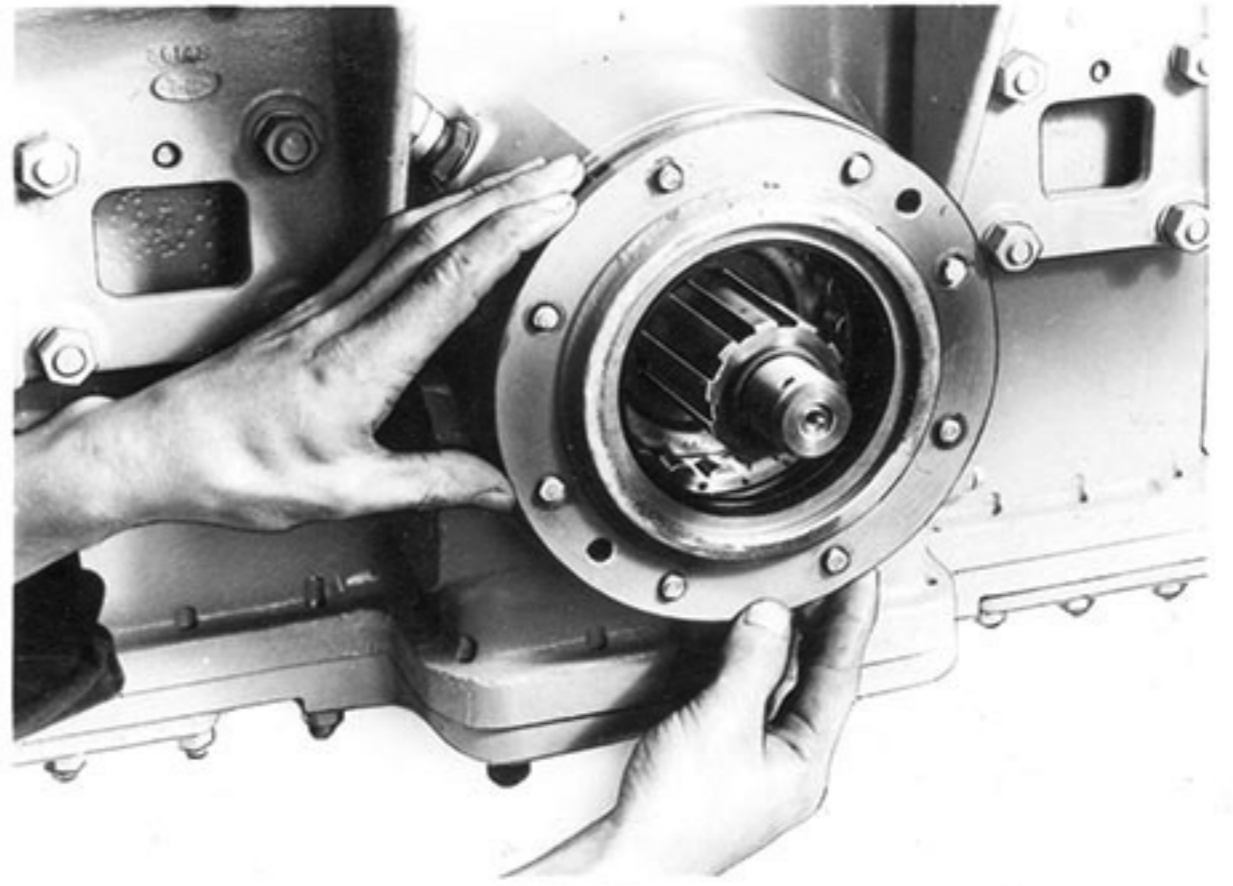

38. FIT THE OIL SEAL HOUSING.

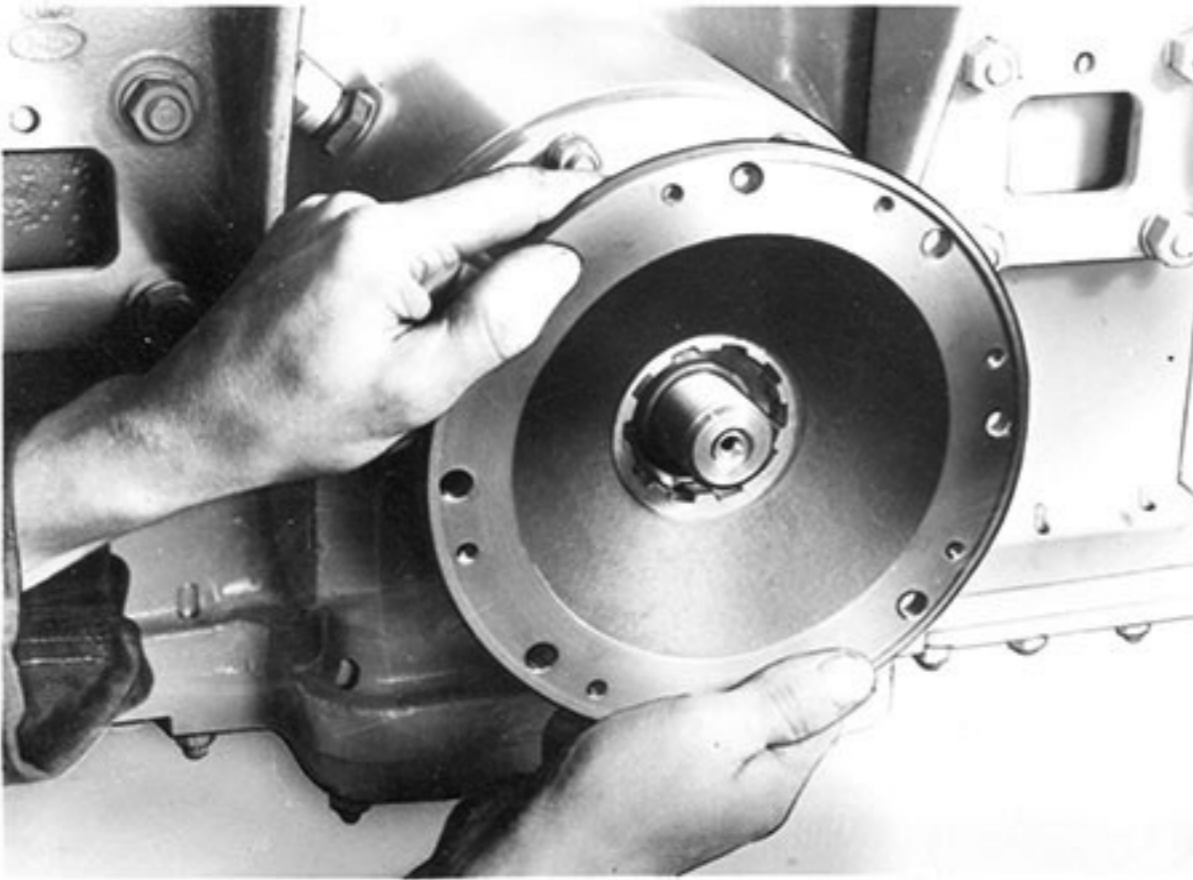

39. THE OUTPUT COUPLING IS NOW FITTED, AND THE "O" RING POSITIONED.

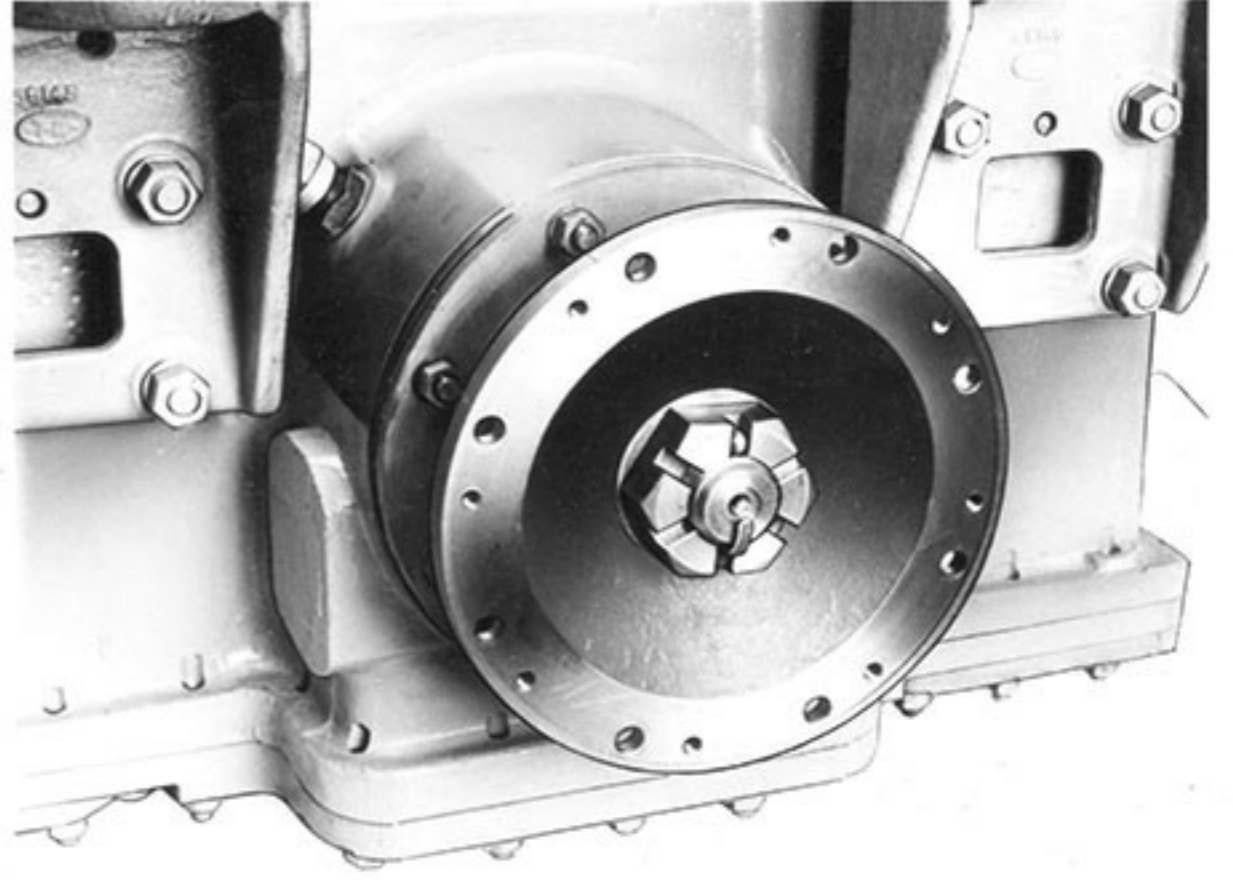

40. SECURE BY FITTING WASHER, NUT AND SPLIT PINS.

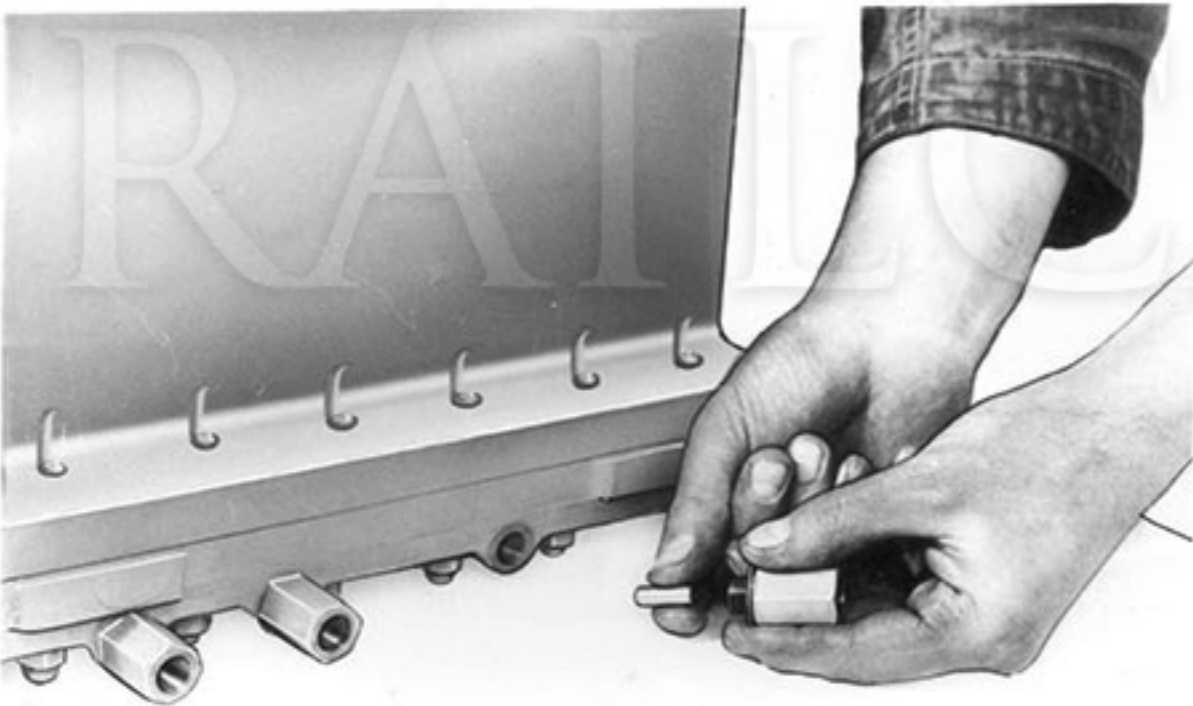

41. THE ADAPTOR AND RESTRICTOR VALVES ARE THEN FITTED.

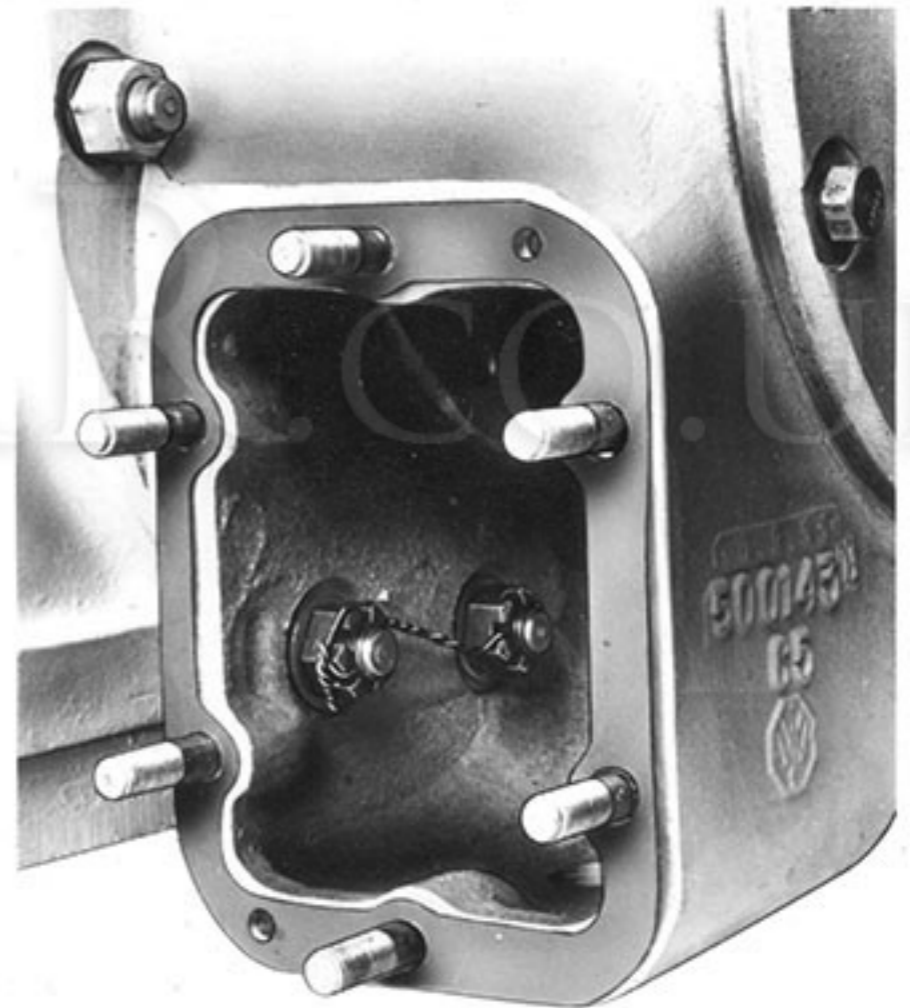

42. WIRE TOGETHER WITH THE CASTELLATED NUTS IN OIL PUMP HOUSING.

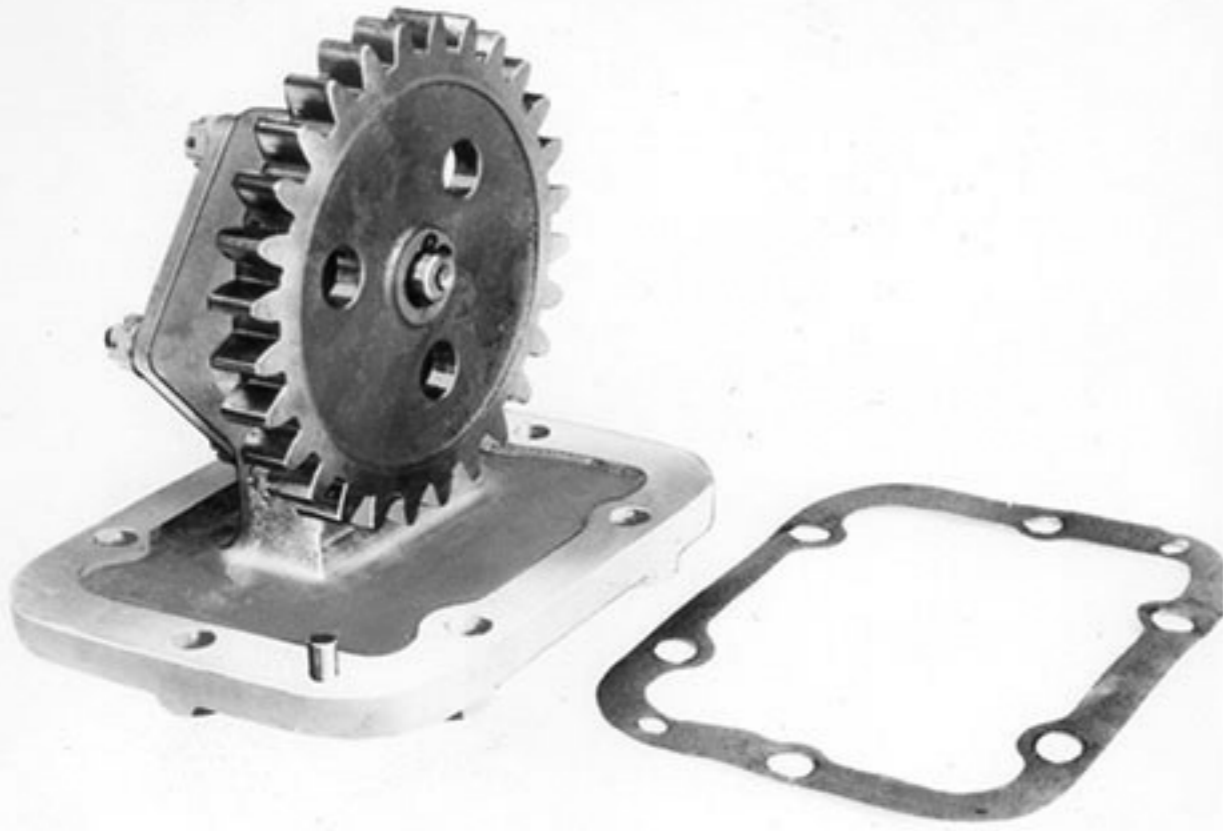

43. THE OIL PUMP AND GASKET.

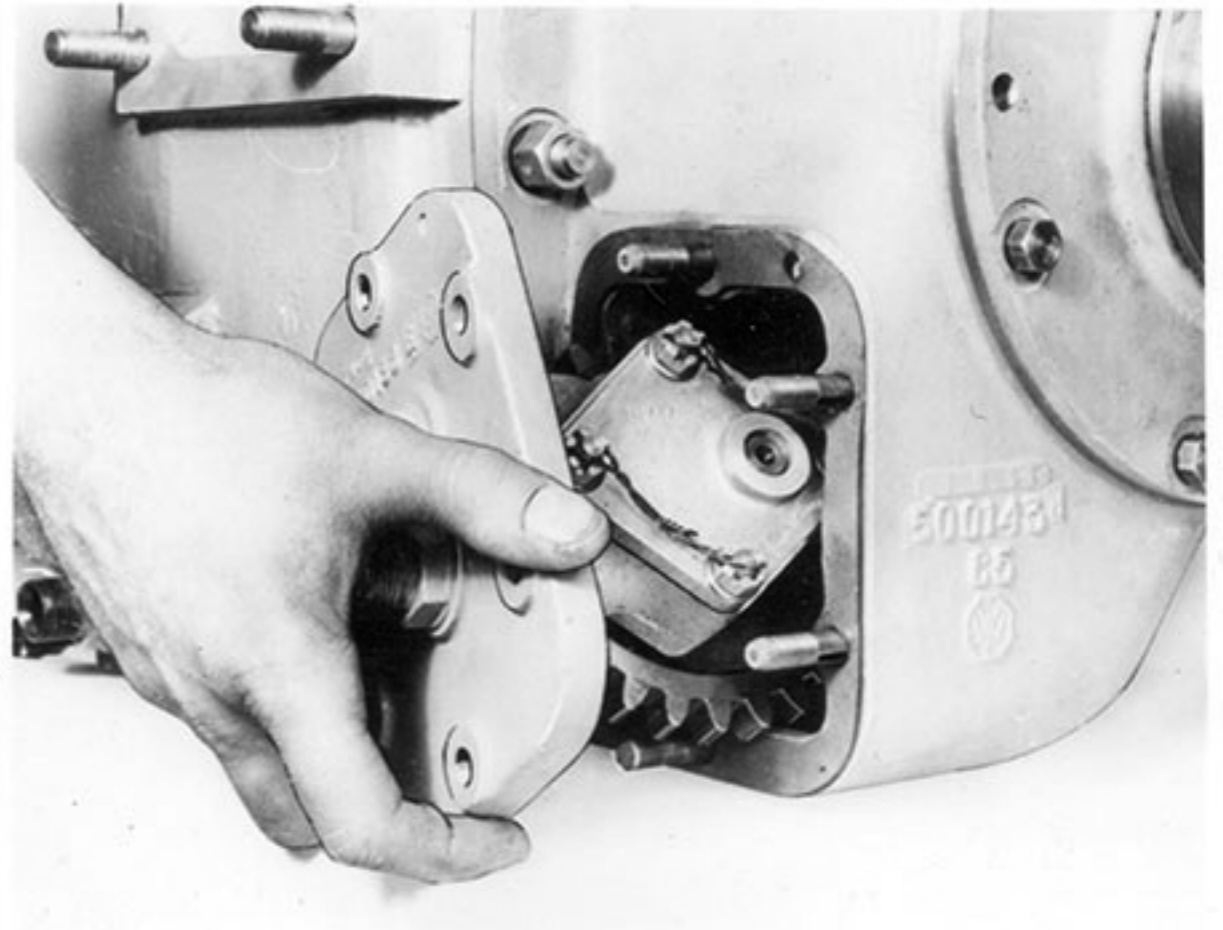

44. THE OIL PUMP IS FITTED.

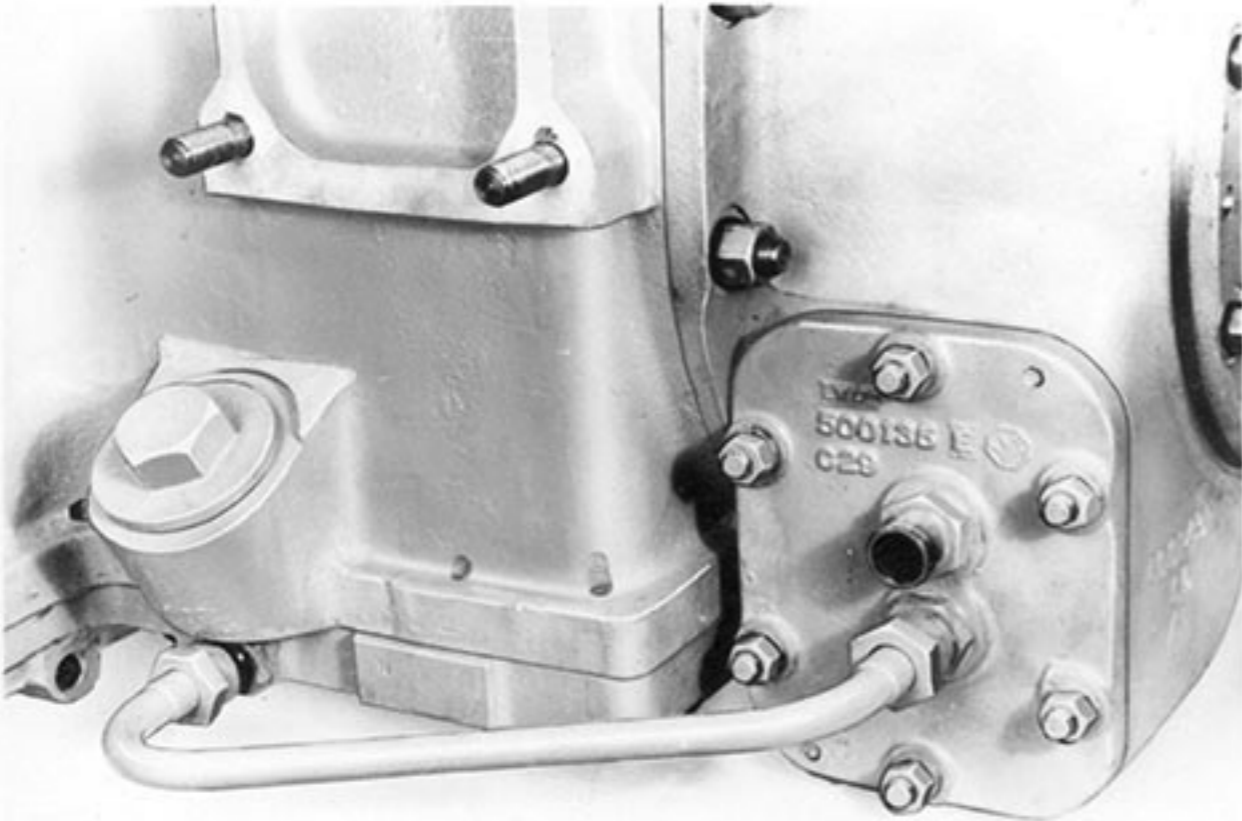

45. THEN THE SUCTION PIPE IS POSITIONED IN THE OIL MUFF.

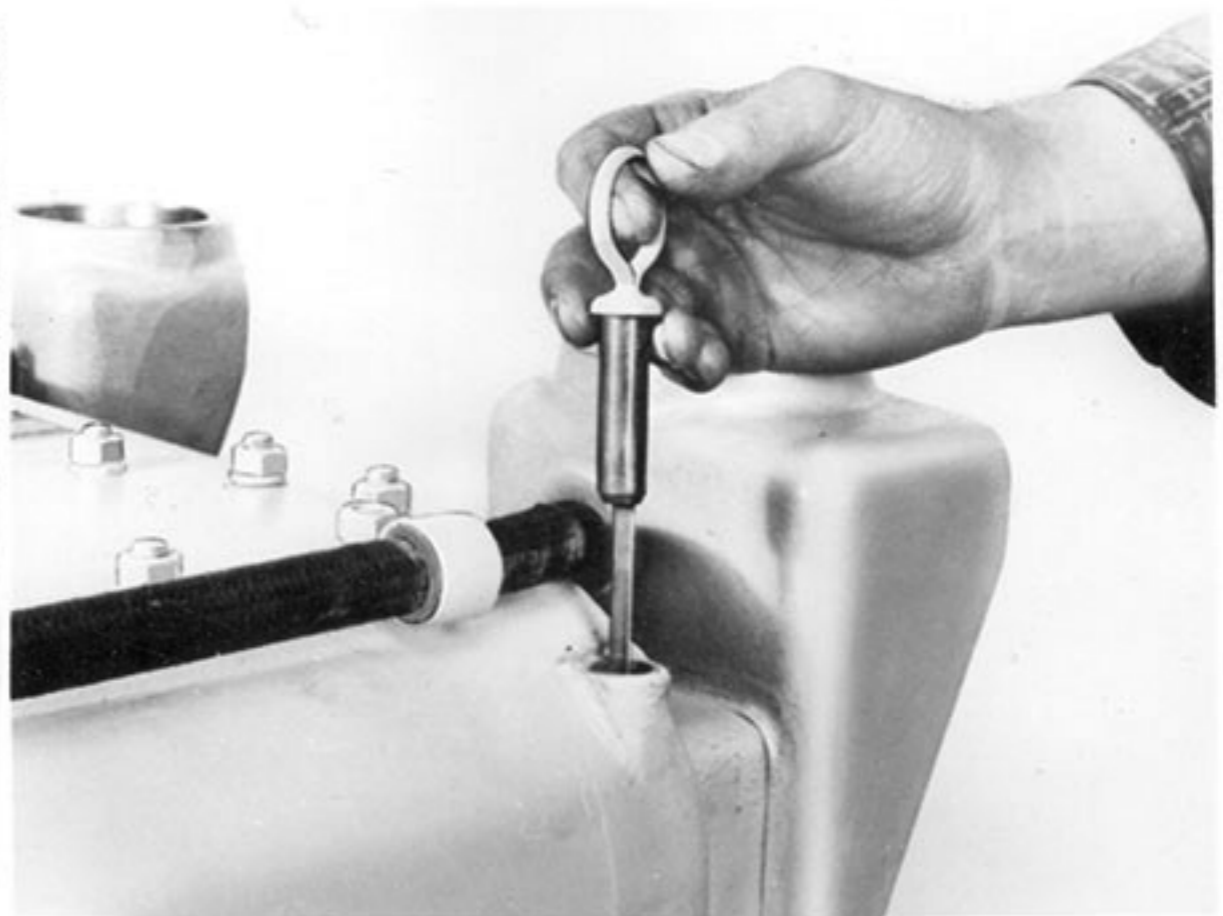

46. THE DIPSTICK IS FITTED.



47. THE FILTER IS FITTED AND THE FLEXIBLE PIPES SECURED.

RAILCAR.CO.UK